

AIR-TO-WATER
**HEAT
PUMP**

2026



UNITHERM R32



UNITHERM R32

SERIES: SPLIT ALL-IN-ONE

Unitherm 4 is a multifunctional heat pump with DC inverter technology that converts heat from the outside air into heat for heating and DHW, and in summer, Unitherm 4 cools water for the air conditioning system. By using the energy from the outside air, the heat pump significantly reduces the cost of heating, hot water supply and air conditioning. A single system with an environmentally friendly refrigerant allows you to obtain cheap thermal energy without negatively impacting the environment.

Unitherm 4 is a latest-generation heat pump with air-to-water technology. It allows you to obtain clean and environmentally friendly energy from the air.

The heat pump actually uses the free heat that our planet gives us.

Unitherm 4 is a 3-in-1 system: heating, hot water supply and air conditioning. A single system that combines all the latest technologies and innovations and meets the needs of different types of premises.

❄️ +10°C ... +48°C
☀️ -25°C ... +35°C



CH-HP 16 SIRK4

Cooper&Hunter

Generation

Heat pump

Power supply:
K – ~220-240V/50 Hz/1 Ph
M – ~380-415V/50 Hz/3 Ph

Nominal heating capacity (kW)

Refrigerant type: R32

S – Split series
 M – Monoblock

DC inverter

AIR-WATER HEAT PUMP WITH DC-INVERTER TECHNOLOGY

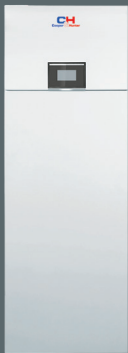

IDU
ALL-IN-ONE

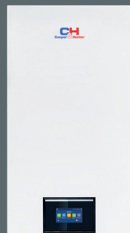

IDU
SPLIT



UNIVERSAL OUTDOOR UNIT FOR SPLIT
AND AIO SERIES

EVOLUTION OF PRODUCT

Cooper&Hunter develops Unitherm heat pumps for many years. Three generations of Unitherm proved to be reliable and durable machines. Unitherm 4 attained the highest standards of quality control (EN14511-2018) and energy efficiency - COP=5,13



THE 1ST GENERATION
UNITHERM
COP = 4.5
(EN14511- 2007)



THE 2ND GENERATION
UNITHERM
COP = 4.55
(EN14511- 2011)



THE 3RD AND 4TH GENERATION
UNITHERM
COP = 5.13
(EN14511- 2018)

FIVE MODES OF OPERATION

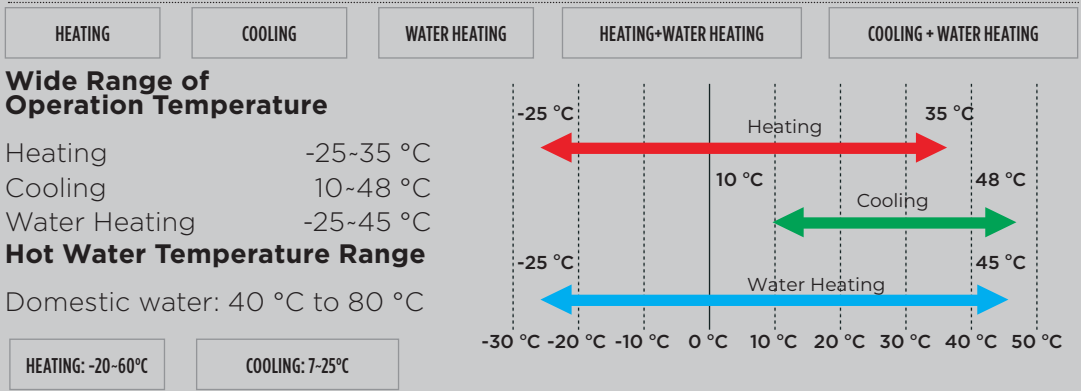

CENTRAL CONTROL OF HEAT PUMPS

The optional CF673 central controller allows you to combine up to 4 heat pumps under one control. This way, you can connect several heat pumps in a cascade and increase the total heat output to 64 kW.

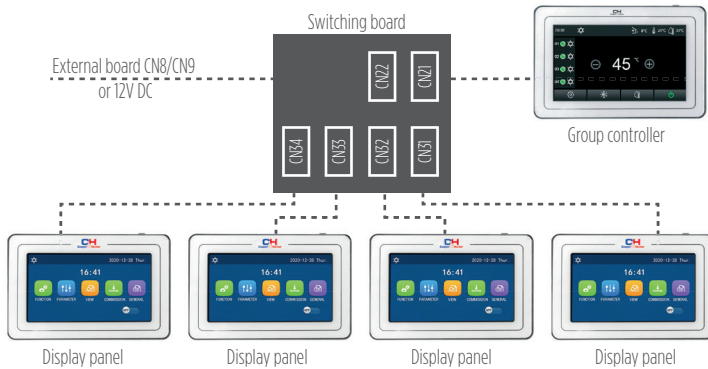

HEAT EXCHANGER



PREVIOUS MODELS
NORMAL FIN



UNITHERM 3 (4):
NEW CHANGED FORM

The new shape of the fins of the heat exchanger increases the heat exchange by 5% in comparison with the previous versions.

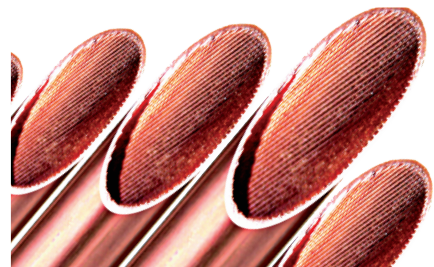

The special thickened groove of the inner copper pipe distributes heat more effectively and increases the heat exchange performance by 8%.

ECONOMICAL ELECTRICITY CONSUMPTION AND SUPER LOW LEVEL OF CO₂ EMISSIONS

Thanks to the heat pump technology, Unitherm 4 uses the thermal energy of the outside air to bring the water temperature to the temperature required for heating and domestic hot water, while consuming a minimum of electricity and with a low level of CO₂ emissions.

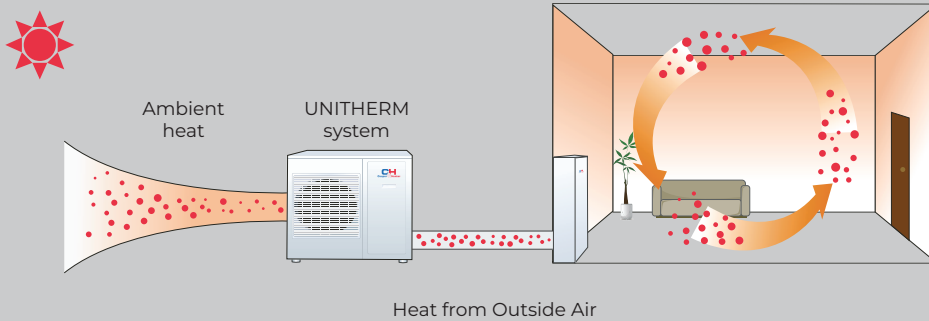

HIGH EFFICIENCY & ENERGY SAVING

The energy efficiency reaches up to 5.13. It adopts a two-stage gas compression and enthalpy increase system, which has a stronger heating capacity at low temperature.

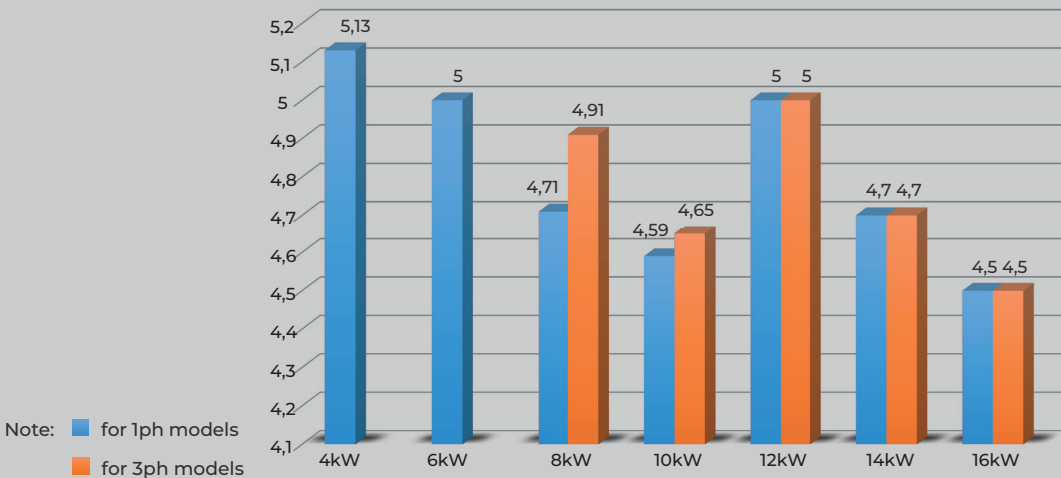

CURRENT LIMIT

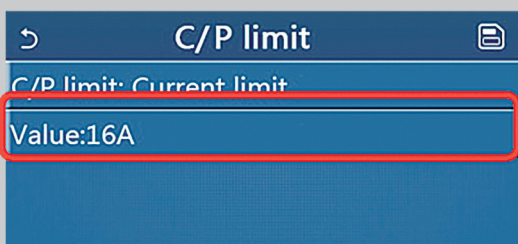

If there is a restriction on the power limit of the power grid at the facility, the customer can set the maximum level of current consumption of the heat pump compressor on the control panel.

SUPER DC-INVERTOR TECHNOLOGY



- **2-stage rotary DC inverter compressor**
Compared to traditional compressors, the two-stage compressor has a higher level of power and energy efficiency, and a wider operating range. Ideal for low-temperature heat pumps;
- **High COP (up to 5.13);**
- **Thanks to the lower discharge temperature, more stable** compressor operation is achieved in extreme operating conditions.

FAN AND MOTOR



The inverter brushless DC motor allows precise control of the device and guarantees reliable energy-efficient operation of the heat pump.

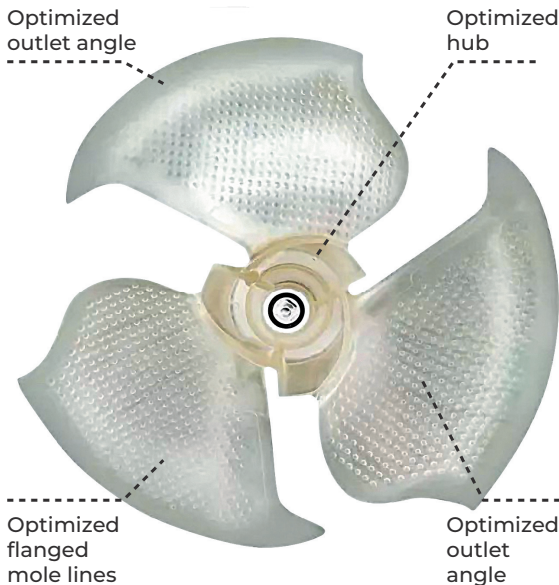

- **DC-inverter (Direct current inverter)**
Effectively provides cooling at low temperatures and heating at high temperatures with a small pressure drop, and also increases the stability of the system.
- **L605 Low Temperature Grease**
with a minimum temperature resistance of -40 °C, effectively solves the noise problem caused by poor engine lubrication at low temperature.
- **CFD modeling of 3D blades:**
tens of thousands of CFD simulations optimized the shape to increase heat transfer and reduce noise by 2 dB (compared to previous versions).

- **EMC motor**

The motor has passed the EMC (electromagnetic compatibility) test, shock resistance, radiation test, resistance to rapid changes in the voltage of the power source. The engine is designed with increased protection against obstacles and high reliability in continuous operation.

RELIABILITY OF THE SYSTEM

Heat exchanger with anti-corrosion coating

The Gold Fin coating with a hydrophobic (water-repellent) effect and high anti-corrosion protection has a longer service life than the previous version with a Blue Fin coating.

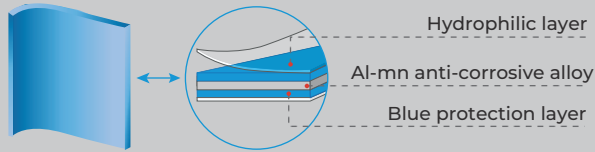

Wide voltage operation range

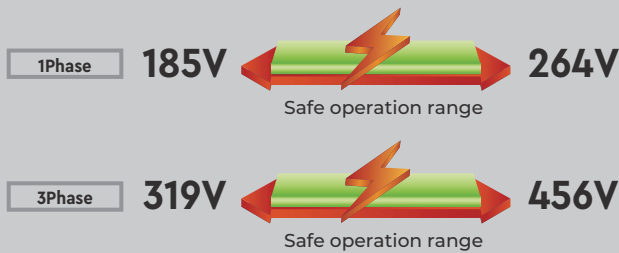

SELF-DIAGNOSIS OF THE OUTDOOR UNIT

If the supply voltage or current exceeds the normal range, the outdoor unit, thanks to the self-diagnosis function, activates automatic protection. If the power is restored to normal parameters, the system will start operation automatically.

ELECTRONIC EXPANSION VALVE (EEV)

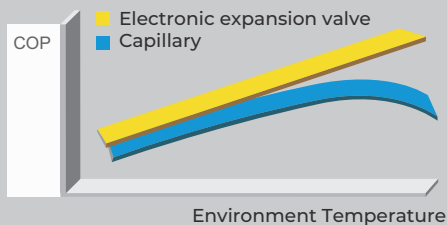

A valve with a wide range of refrigerant flow, which can automatically adjust the throttle according to the required amount of refrigerant. EEV is more energy-saving and stable than TRV and capillary throttling.

COMFORT

Precise temperature regulation

EEV guarantees automatic adjustment according to parameters and water temperature.

Quiet mode

By adjusting the power of the compressor and the fan, the operating noise of the device can be reduced by 3 dB(A), which meets the requirements of night mode or special circumstances.

DISINFECTION OF DOMESTIC HOT WATER (DHW)

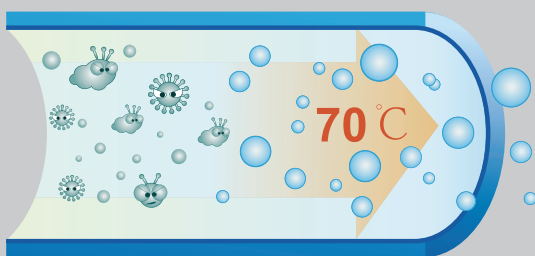

Domestic water that meets the sanitary requirements can be used without additional treatment.

The tank and heat exchanger do not affect the quality of water in the system.

The disinfection function (heating the water to a temperature of 70 °C) prevents the growth of bacteria.

HIGH EFFICIENCY

High COP plate heat exchanger

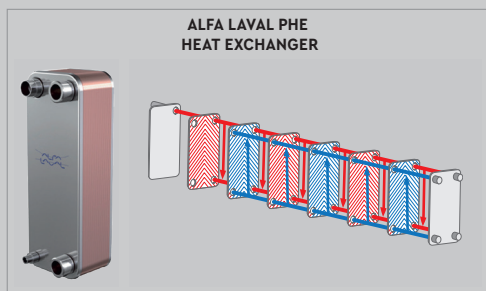

ALFA LAVAL PHE
HEAT EXCHANGER

Highly efficient pump



DANFOSS PHE
ECONOMIZER

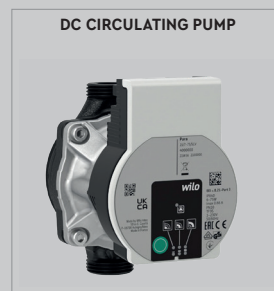

DC CIRCULATING PUMP

INTELLIGENT TEMPERATURE CONTROL

Advanced system management capabilities are integrated into the automation of the indoor unit (hydro module). The timer can be programmed for an hour or a day. In this way, the temperature drops automatically, but will be comfortably warm when you wake up or come home.

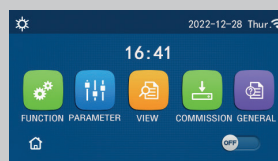

ENVIRONMENT-DEPEND MODE



Automatically calculates the capacity demand (heating/cooling) in the room according to the temperature of the outside environment for energy savings and comfort.

WI-FI MODULE

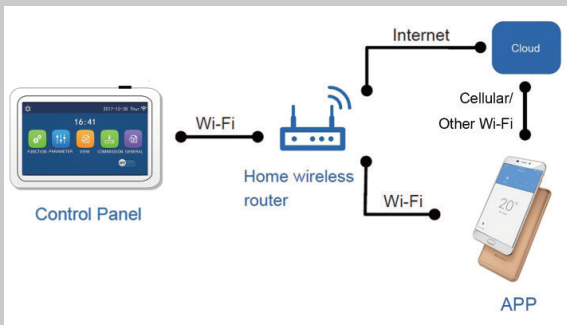

The **display panel** comes with a built-in **Wi-Fi module**, which opens up a wide range of convenient control options. For remote access to the device's functionality, a specialised mobile application, **EWPE SMART**, is used, which can be downloaded to your smartphone or tablet. This allows you to fully control the heat pump from anywhere with internet access, ensuring maximum comfort and flexibility of use.

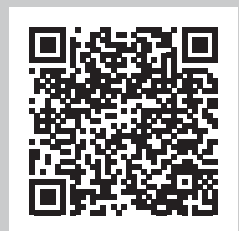
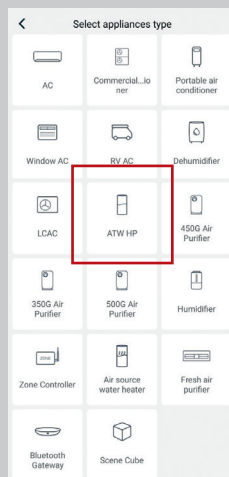
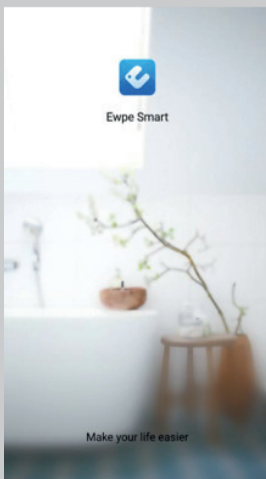

FREEZING PROTECTION

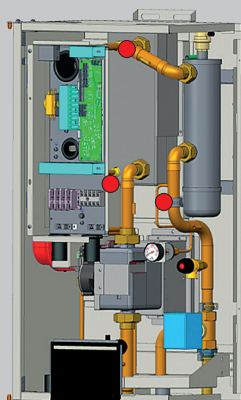

When the device is not working, in order to avoid freezing of components and pipelines on the water side due to low ambient temperature, the integrated three temperature sensors work constantly.

When the detected temperature at any sensor is less than 3 °C, the device will start the water pump to circulate the water in the system. If the temperature continues to drop below 2 °C, the unit enters heating mode and will not exit it until the water temperature reaches 20 °C.

Note:

- Freeze protection temperature sensor

ADJUSTMENT OF OPERATION ACCORDING TO TIME

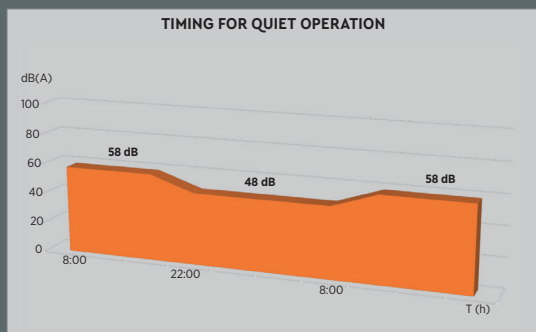

1. Settable time for quiet operation
2. Quiet operation for sleeping

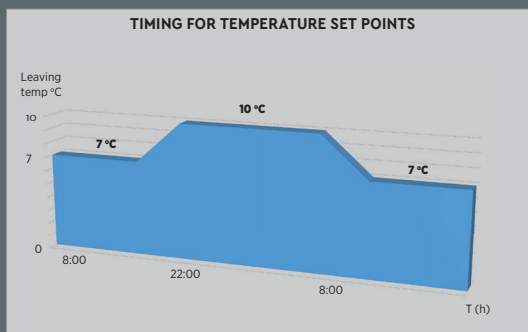

1. Two time periods can be set
2. Different temperature regimes for different periods of time

OUT MODE

When the outside temperature is below 0 °C, to avoid freezing of the elements in contact with water, you can activate **OUT MODE** to maintain the indoor temperature around 10 °C with low energy consumption.

The device maintains low power consumption and the indoor temperature is around 10 °C.

1. Under room temperature control, 10 °C is programmed by default.
2. Under water temperature control, the default programmed temperature is 30 °C.

SEVERAL ADDITIONAL USER-FRIENDLY FUNCTIONS

- **Emergency water heating**

The heat pump uses a backup electric heater in case of any malfunction.

- **Floor protection**

The heat pump uses a backup electric heater in case of any malfunction.

- **Underfloor heating**

To avoid damaging the floor covering, the default maximum water temperature is 45 °C. If the design includes a mixing unit for underfloor heating with its own automation, the maximum heat transfer fluid temperature can be changed to 55 °C.

- **Cold ceiling (floor)**

To prevent condensation that could damage the floor or other surfaces, the default minimum water temperature is 18 °C. If the project only includes fan coils for cooling, the minimum cold ceiling temperature limit can be changed to 7 °C.

- **Rapid water heating**

The heat pump and electric water tank heater operate simultaneously for rapid heating.

- **Disinfection**

The water will be heated to 70 °C at a set time to destroy bacteria in the water. Disinfection is usually carried out at night.

- **Holiday mode**

During winter holidays, the device can be set to automatic operation to maintain the room temperature within 10-15 °C.

- **Weather-dependent operation**

The device can automatically adjust its operating mode according to the temperature range set by the user.

- **Convenient and large LED display.**

- **On/off timer**

Daily/weekly countdown timer

Weekly program

- **Emergency operation mode**

(only for heating and water heating)

- **Forced operation mode**

- **Silent mode**

- **Central control**



EMERGENCY

When a malfunction occurs in the outdoor unit of the heat pump that prevents it from functioning normally and requires urgent repair, the system provides the option of activating emergency mode. This allows the user to meet their basic heating and hot water needs despite the failure of the main unit.

How emergency mode works

In emergency mode, auxiliary electric heaters are activated instead of the compressor and other components of the outdoor unit that have failed. They start working simultaneously to perform two key tasks:

Space heating: Electric heaters built into the indoor unit generate heat, which is then distributed through the heating system (radiators, underfloor heating), maintaining a comfortable temperature in the house.

Hot water heating: At the same time, an electric heater in the hot water tank (HWT) operates, ensuring a constant supply of hot water for domestic needs such as showering or washing dishes.

This mode is a temporary solution that allows you to avoid interruptions in comfort until a service technician arrives. It ensures stable operation of the system until the outdoor unit is fully restored to functionality.

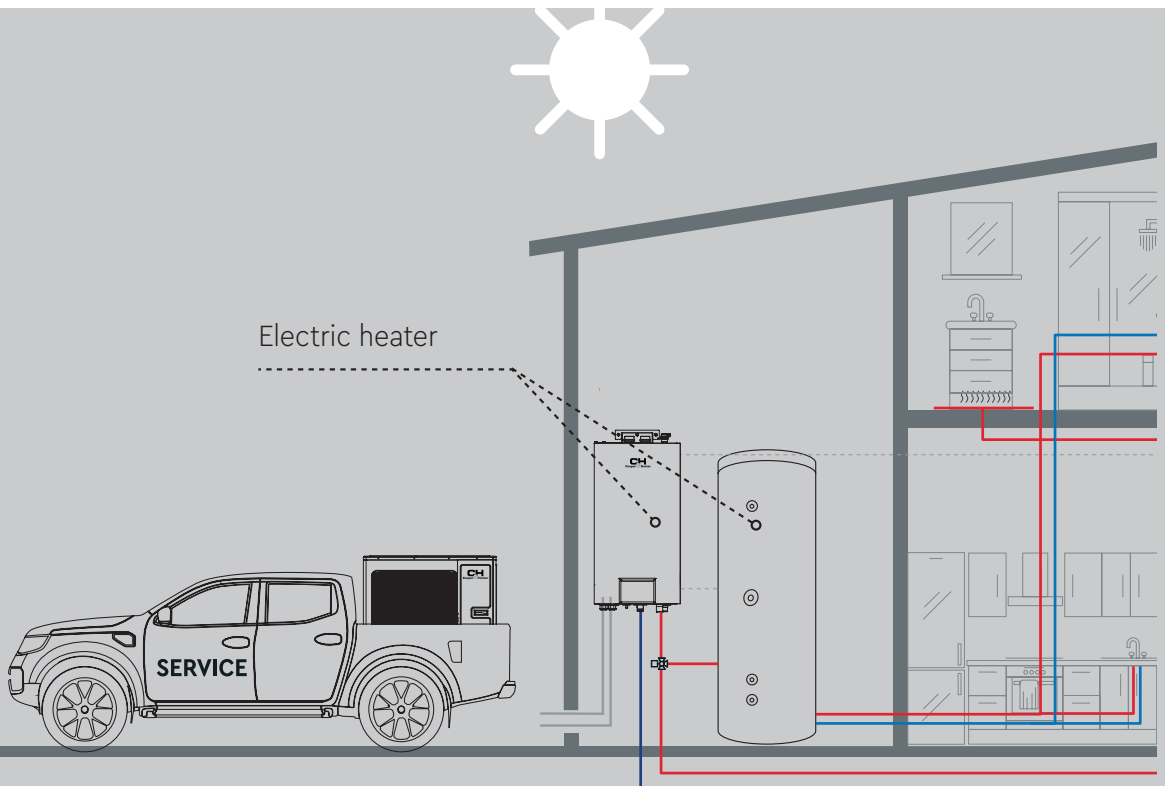

UNITHERM 4 SPLIT R32 SERIES

INVERTER

R32

❄️ +10°C ... +48°C

☀️ -25°C ... +35°C



- ❄️
-25°C...
+48°C
- 🌊 +60°C
Max. water
temperature
- 🔋 A+++
Energy
Efficiency
- 🗣️
Self-diag-
nostics
- 🛡️
Auto-pro-
tection
- 🛡️
Anti-cor-
rosive
Coating
- 🔧
2-Stage
Compressor
- 🕒 24h
Timer
- 📺
Wired
Controller
- 🏠
BMS Control
Systems
- 💧
Intelligent
Defrosting
- 🧠
Intelligent
Control
- 📶
Wi-Fi

COMPACT AND FLEXIBLE DESIGN OF INDOOR UNIT

Compact design, easy to install.

Dimensions (W×D×H) (mm)

460×318×860 mm

Safety valve, plate heat exchanger, expansion tank, circulation pump and control unit, all in one device.



See the table below regarding the configuration of E-heater for heating and connecting E-heater for domestic hot water.

	E-heater for heating (built-in)	E-heater for DHW (external)
CH-HP6.0SIRK4(I)	1.5 + 1.5 kW	3 kW
CH-HP8.0SIRK4(I) CH-HP10SIRK4(I)	3 + 3 kW	3 kW
CH-HP12SIRK(M)4(I) CH-HP14SIRK(M)4(I) CH-HP16SIRK(M)4(I)	3 + 3 kW	3 kW

INDOOR UNIT (HYDROMODULE): HEATING/COOLING AND DHW

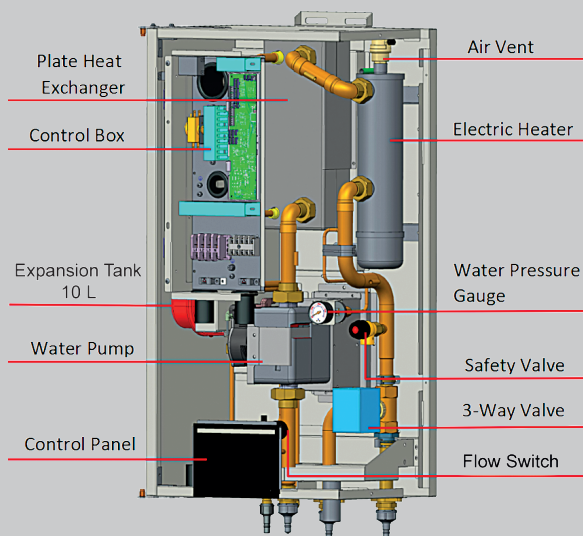

The indoor unit (hydromodule) regulates the supply of heat/cold/DHW to heating floor/convectors/fancoils, etc.

You can manage your comfort:

changing the temperature and water supply, adjust the modes through the central controller installed on the indoor unit (hydromodule).

TECHNICAL PARAMETERS OF UNIT SPLIT SERIES 1 PHASE

			CH-HP6.0SIRK4	CH-HP8.0SIRK4	CH-HP10SIRK4	CH-HP12SIRK4	CH-HP14SIRK4	CH-HP16SIRK4
Capacity *	Cooling	kW	5.80	7.00	8.50	11.00	12.60	13.00
	Heating	kW	6.00	8.00	9.50	12.00	14.00	15.50
Power input*	Cooling	kW	1.32	1.75	2.24	2.50	3.41	3.60
	Heating	kW	1.20	1.70	2.07	2.40	2.98	3.44
EER* ¹			4.40	4.00	3.80	4.40	3.70	3.60
COP* ¹			5.00	4.70	4.60	5.00	4.70	4.50
Capacity **	Cooling	kW	4.09	5.30	6.50	10.59	11.07	11.51
	Heating	kW	5.90	8.00	9.50	12.40	14.48	16.09
Power input**	Cooling	kW	1.28	1.73	2.27	3.79	4.18	4.49
	Heating	kW	1.51	2.14	2.64	3.29	3.93	4.44
EER**			3.20	3.00	2.90	2.79	2.65	2.57
COP**			3.90	3.70	3.60	3.77	3.68	3.62
Refrigerant charge volume		kg	1.00	1.60	1.60	1.84	1.84	1.84
Power supply			-220-240V/50 Hz/1 Ph					
Sound pres-sure level	Colling	dB (A)	52	55			68	
	Heating	dB (A)	52	55			68	
Dimensions (W×D×H)	Indoor unit	mm	460x318x860					
	Outdoor unit	mm	975x396x702	982x427x787			940x460x820	
Net weight	Indoor unit	kg	62					
	Outdoor unit	kg	55	82			110	
Water circulating pipe inlet/outlet, DHW			1" Male BSP					
Diameter of pipe	Liquid	inch (mm)	1/4" (6.35)					
	Gas	inch (mm)	1/2" (12.7)			5/8" (15.6)		

NOTE

«*» capacity and power input are specified under the following conditions:

Cooling Water temperature: +23°C/+18°C; Outdoor temperature: +35°C DB; +24°C WB

Heating Water temperature: +30°C/+35°C; Outdoor temperature: +7°C DB; +6°C WB

«**» capacity and power input are specified under the following conditions:

Cooling Water temperature: +12°C/+7°C; Outdoor temperature: +35°C DB; +24°C WB

Heating Water temperature: +40°C/+45°C; Outdoor temperature: +7°C DB; +6°C WB

TECHNICAL PARAMETERS OF UNIT SPLIT SERIES 3 PHASE

			CH-HP12SIRM4	CH-HP14SIRM4	CH-HP16SIRM4
Capacity *	Cooling	kW	11.00	12.60	13.00
	Heating	kW	12.00	14.00	15.50
Power input*	Cooling	kW	2.50	3.41	3.60
	Heating	kW	2.40	2.98	3.44
EER* ¹			4.40	3.70	3.60
COP* ¹			5.00	4.70	4.51
Capacity **	Cooling	kW	10.65	11.24	11.52
	Heating	kW	12.29	14.44	16.13
Power input**	Cooling	kW	3.74	4.13	4.38
	Heating	kW	3.09	3.63	4.16
EER **			2.85	2.72	2.63
COP **			3.98	3.98	3.88
Refrigerant charge volume	kg	1.84		1.84	1.84
Power supply	-380-415V/50 Hz/3 Ph				
Sound pressure level	Cooling	dB (A)	68	68	68
	Heating	dB (A)	68	68	68
Dimensions (W×D×H)	Indoor unit	mm	460x318x860	460x318x860	460x318x860
	Outdoor unit	mm	940x460x820	940x460x820	940x460x820
Net weight	Indoor unit	kg	62	62	62
	Outdoor unit	kg	110	110	110
Water circulating pipe inlet/outlet, DHW			1" Male BSP	1" Male BSP	1" Male BSP
Diameter of pipe	Liquid	inch (mm)	1/4" (6,35)	1/4" (6,35)	1/4" (6,35)
	Gas	inch (mm)	5/8" (15,9)	5/8" (15,9)	5/8" (15,9)

NOTE

«*» capacity and power input are specified under the following conditions:

Cooling Water temperature: +23°C/+18°C; Outdoor temperature: +35°C DB; +24°C WB

Heating Water temperature: +30°C/+35°C; Outdoor temperature: +7°C DB; +6°C WB

«**» capacity and power input are specified under the following conditions:

Cooling Water temperature: +12°C/+7°C; Outdoor temperature: +35°C DB; +24°C WB

Heating Water temperature: +40°C/+45°C; Outdoor temperature: +7°C DB; +6°C WB

ELECTRICAL PARAMETERS OF UNUTHERM 4 SPLIT

	Power supply	Automatic switch (A)	The minimum cross-sectional area of the grounding wire (mm ²)	The minimum cross-sectional area of the power cable (mm ²)
CH-HP6.OSIRK4(O)	-220-240V/50 Hz/1 Ph	16	15	15
CH-HP6.OSIRK4(I)		20	6	6
CH-HP8.OSIRK4(O)		25	4	4
CH-HP8.OSIRK4(I)		40	6	6
CH-HP10SIRK4(O)		25	4	4
CH-HP10SIRK4(I)		40	6	6
CH-HP12SIRK4(O)		32	6	6
CH-HP12SIRK4(I)		40	6	6
CH-HP14SIRK4(O)		40	6	6
CH-HP14SIRK4(I)		40	6	6
CH-HP16SIRK4(O)		40	6	6
CH-HP16SIRK4(I)		40	6	6
CH-HP12SIRM4(O)	-380-415V/50 Hz/3 Ph	16	2.5	2.5
CH-HP12SIRM4(I)		20	4	4
CH-HP14SIRM4(O)		16	2.5	2.5
CH-HP14SIRM4(I)		20	4	4
CH-HP16SIRM4(O)		16	2.5	2.5
CH-HP16SIRM4(I)		20	4	4

NOTE

- If circuit breakers with leakage protection are used, the trip time should be less than 0.1 second and the leakage current should be 30 mA.
- The diameter of the power cables selected above is determined based on the assumption that the distance from the distribution box to the device is less than 75 m. If the cables are laid at a distance of 75 to 150 m, then the diameter of the power cable must be increased.
- The power source must meet the rated voltage of the device and must be connected to a separate electrical line.
- All electrical work must be performed by professional technicians in accordance with local codes and ordinances.
- Implement safety grounding. The grounding wire must be connected to a special grounding line in the building, the connection must be made by professional technicians.
- The switch and power cord specifications in the table above are based on the maximum power (maximum current) of the device.
- The power cable specifications in the table above refer to a stranded copper cable in a protective sheath (e.g. YJV cross-linked polyethylene insulated power cable) used at +40 °C and resistant to +90 °C (see IEC 60364-5-52). If the requirements are changed, the cables must be replaced according to the relevant standard.
- The switch specifications in the table above refer to the switch with an operating temperature of +40 °C. In the event of a change in conditions, they must be changed in accordance with the current national standard.
- An automatic switch must be installed in the power supply line. Automatic switch with disconnection of all poles. The opening distance between the contacts should be at least 3 mm.

PIPE CONNECTION OF UNITHERM 4 SPLIT

	Diameter tube		Length B		Height A		Additional
	GAS	Liquid	Std	Max	Std	Max	Refrigerant
CH-HP6.0SIRK4	1/2"	1/4"	5 m	20 m	0 m	15 m	16 g/m
CH-HP8.0SIRK4	1/2"	1/4"	5 m	25 m	0 m	15 m	16 g/m
CH-HP10SIRK4	1/2"	1/4"	5 m	25 m	0 m	15 m	16 g/m
CH-HP12SIRM4	5/8"	1/4"	5 m	15 m*	0 m	15 m	0 g/m
CH-HP14SIRM4	5/8"	1/4"	5 m	15 m*	0 m	15 m	0 g/m
CH-HP16SIRM4	5/8"	1/4"	5 m	15 m*	0 m	15 m	0 g/m
CH-HP12SIRK4	5/8"	1/4"	5 m	15 m*	0 m	15 m	0 g/m
CH-HP14SIRK4	5/8"	1/4"	5 m	15 m*	0 m	15 m	0 g/m
CH-HP16SIRK4	5/8"	1/4"	5 m	15 m*	0 m	15 m	0 g/m

* Under certain conditions, the length can be increased to 25 m.

NOTES:

- Additional refrigerant charging is not required if the pipe length is less than 10m, if the pipe length is more than 10m, additional refrigerant charging is required according to the table. For example: if a 10 kW model is installed at a distance of 25 m, you should add $(25-10) \times 16 = 240$ g of refrigerant.
- Rated capacity is based on standard pipe length and maximum allowable length is based on working length. The grease intake loop should be installed every 5-7 meters if the external unit is located above the internal unit (hydro module).
- Each 90° bend is approximately equal to 0.5 meters of pipe length.

OVERALL DIMENSIONS OF THE INDOOR UNIT (HYDROMODULE)

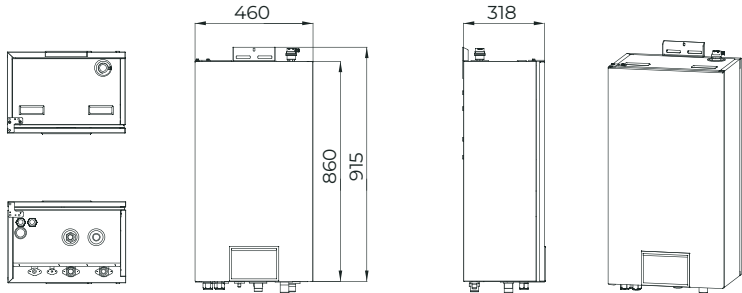

Nº.	Description	Connection thread
1	Diameter of outlet pipe (water)	1" Male BSP
2	Diameter of return water flow pipe	1" Male BSP
3	Liquid pipe	1/4" CH-HP8.0SIRK4(I), CH-HP10SIRK4(I), CH-HP12SIRM4(I), CH-HP14SIRM4(I), CH-HP16SIRM4(I), CH-HP12SIRK4(I), CH-HP14SIRK4(I), CH-HP16SIRK4(I)
4	Gas pipe	1/2" CH-HP8.0SIRK4(I), CH-HP10SIRK4(I)
5	Gas pipe	5/8" CH-HP12SIRM4(I), CH-HP14SIRM4(I), CH-HP16SIRM4(I), CH-HP12SIRK4(I), CH-HP14SIRK4(I), CH-HP16SIRK4(I)

OVERALL DIMENSIONS OF THE OUTDOOR UNIT

CH-HP6.OSIRK4 (O)

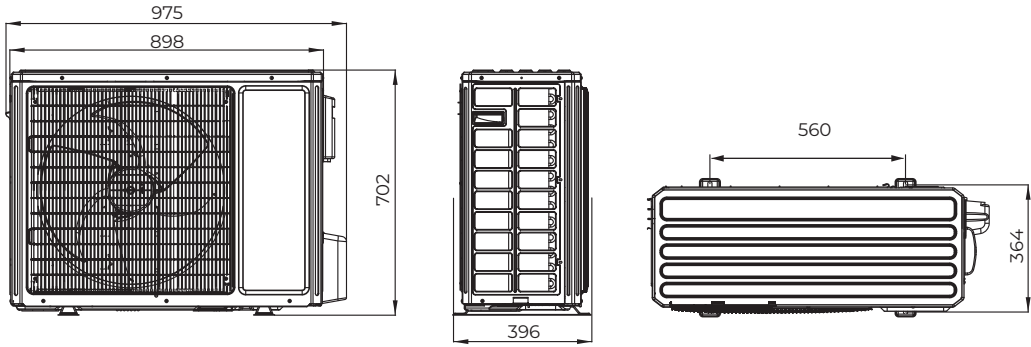

CH-HP8.OSIRK4 (O), CH-HP10SIRK4 (O)

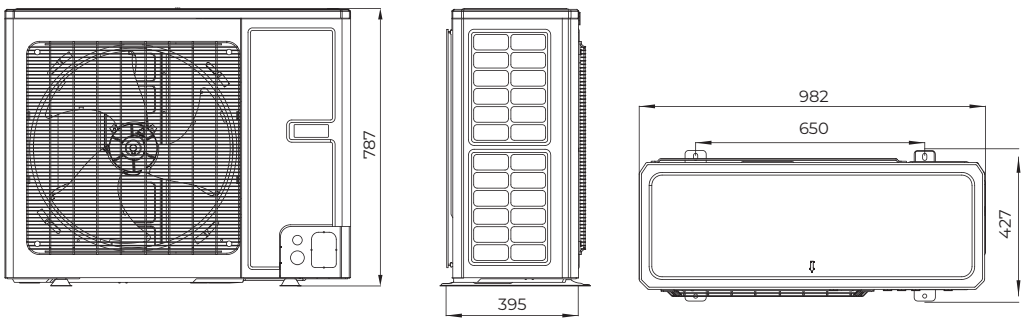

**CH-HP12SIRM4(O) , CH-HP14SIRM4(O), CH-HP16SIRM4(O),
CH-HP12SIRK4(O) ,CH-HP14SIRK4(O), CH-HP16SIRK4(O)**

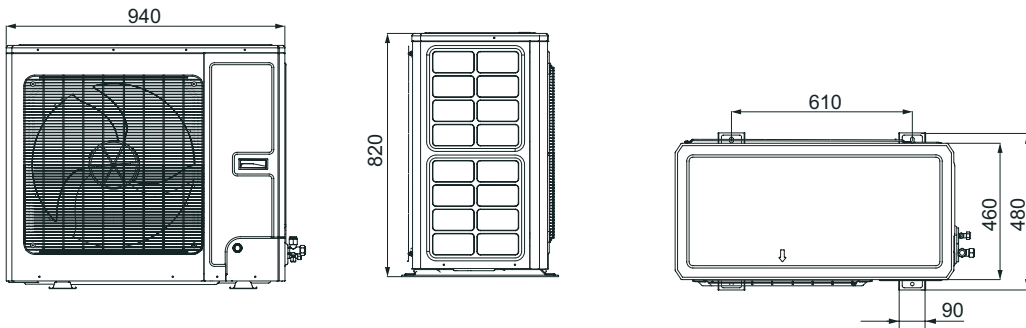

UNITHERM 3 ALL-IN-ONE R32

SERIES

INVERTER  R32

 +10°C ... +48°C

 -25°C ... +35°C



-25°C...
+48°C



+60°C
Max. water temperature



Energy Efficiency



Self-diagnos-
tics



Auto-pro-
tection



Anti-cor-
rosive
Coating



2-Stage
Compressor



Timer



Wired
Controller



BMS Control
Systems



Intelligent
Defrosting



Intelligent
Control



Wi-Fi

INDOOR UNIT

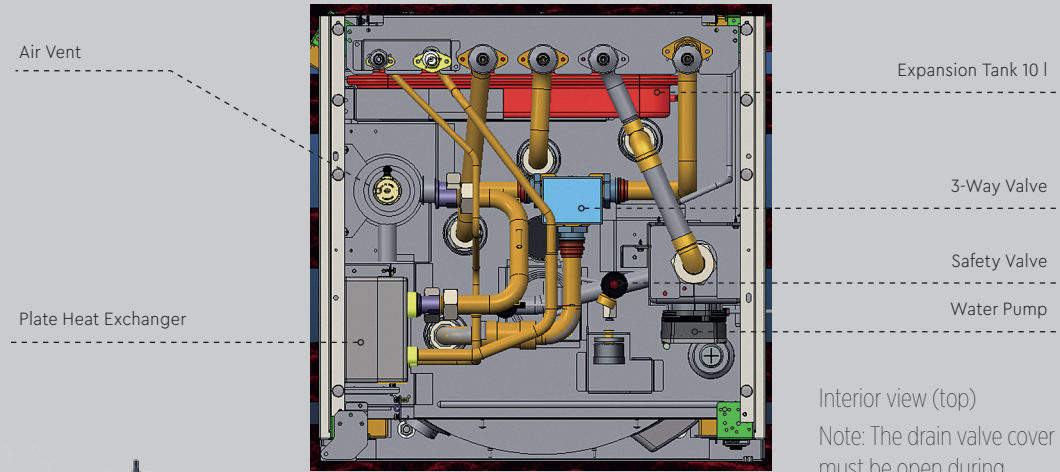

Interior view (top)
 Note: The drain valve cover must be open during installation

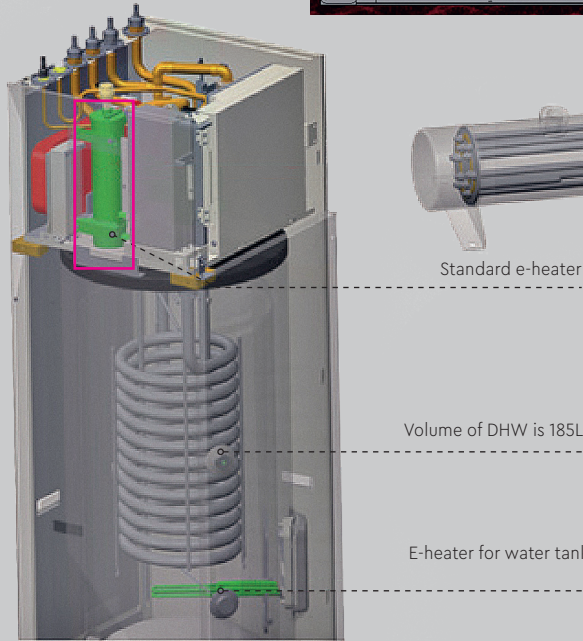

See the table below regarding the configuration of the electric heater for heating and domestic hot water.

	E-heater for heating	E-heater for DHW
CH-HP6.0WTSIRK3(I)	15+15 kW	3 kW
CH-HP8.0WTSIRK3(I)	3+3 kW	3 kW
CH-HP10WTSIRK3(I)		
CH-HP12WTSIRK3(I)		
CH-HP14WTSIRK3(I)	3+3 kW	3 kW
CH-HP16WTSIRK3(I)		

OUTDOOR UNIT IS UNIVERSAL FOR SPLIT AND ALL-IN-ONE SERIES

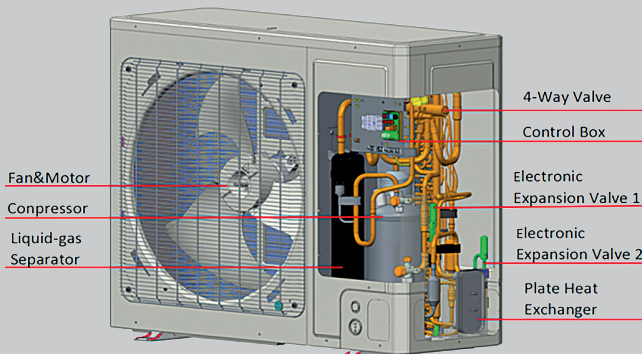

Two-Stage technology enables efficient heating of water at extremely low temperatures without additional losses of electricity

ALL-IN-ONE SERIES WITH BUILT-IN DHW WATER TANK

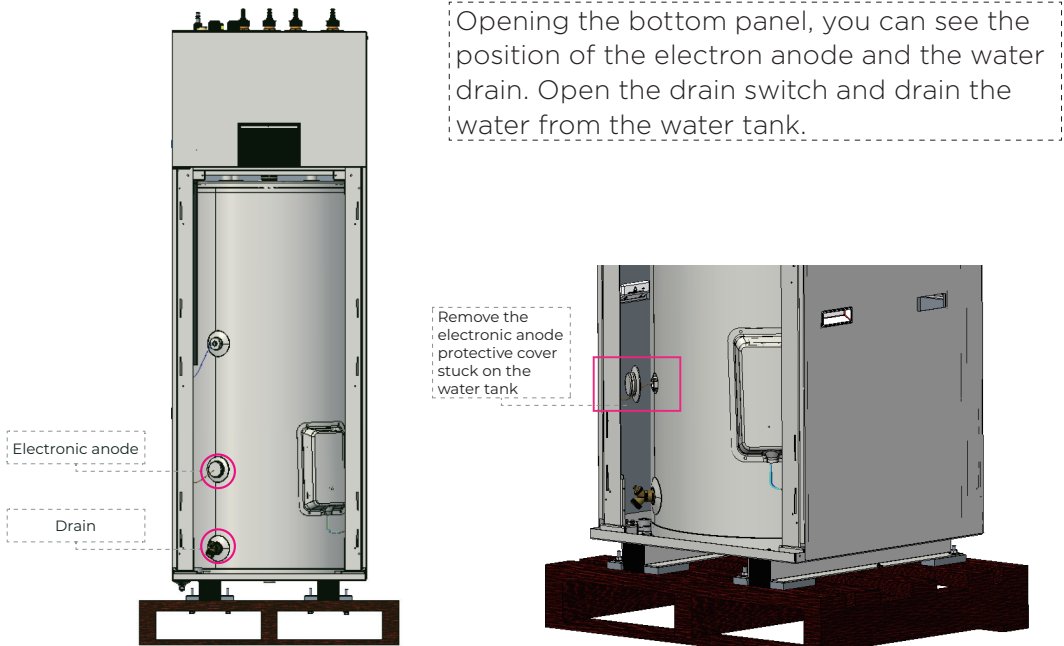

OVERALL DIMENSIONS OF INDOOR UNITS

No.	Description	Connection thread
1	Diameter of outlet pipe (water)	1" Male BSP
2	Diameter of return water flow pipe	1" Male BSP
3	Tap water	1" Male BSP
4	DHW	1" Male BSP
5	Liquid pipe	1/4"
6	Gas pipe	1/2"
7	Gas pipe	5/8"

Model	Height	Width	Depth
CH-HP4.0WTSIRK4(I), CH-HP6.0WTSIRK4(I), CH-HP8.0WTSIRK4(I), CH-HP10WTSIRK4(I), CH-HP12WTSIRK4(I), CH-HP14WTSIRK4(I), CH-HP16WTSIRK4(I), CH-HP8.0WTSIRM4(I), CH-HP10WTSIRM4(I), CH-HP12WTSIRM4(I), CH-HP14WTSIRM4(I), CH-HP16WTSIRM4(I)	1695	600	600
CH-HP4.0WTSIRK4(I), CH-HP6.0WTSIRK4(I), CH-HP8.0WTSIRK4(I), CH-HP10WTSIRK4(I), CH-HP8.0WTSIRM4(I), CH-HP10WTSIRM4(I)	1756	600	600

TECHNICAL PARAMETERS OF ALL IN ONE SERIES 1 PHASE

			CH- HP6.0WTSIRK3	CH- HP8.0WTSIRK3	CH- HP10WTSIRK3	CH- HP12WTSIRK3	CH- HP14WTSIRK3	CH- HP16WTSIRK3
Capacity*	Cooling	kW	5.80	7.00	8.50	11.00	12.60	13.00
	Heating	kW	6.00	8.00	9.50	12.00	14.00	15.50
Power input*	Cooling	kW	1.32	1.75	2.24	2.50	3.41	3.60
	Heating	kW	1.20	1.70	2.07	2.40	2.98	3.44
EER *			4.40	4.00	3.80	4.40	3.70	3.60
COP*			5.00	4.70	4.60	5.00	4.70	4.50
Capacity*	Cooling	kW	4.09	5.30	6.50	10.59	11.07	11.51
	Heating	kW	5.90	8.00	9.50	12.40	14.48	16.09
Power input*	Cooling	kW	1.28	1.73	2.27	3.79	4.18	4.49
	Heating	kW	1.51	2.14	2.64	3.29	3.93	4.44
EER **			3.20	3.00	2.90	2.79	2.65	2.57
COP **			3.90	3.70	3.60	3.77	3.68	3.62
Refrigerant charge volume	kg		1.00	1.60	1.60	1.84	1.84	1.84
Power supply	-220-240V/50 Hz/1 Ph							
Sound pressure level	Cooling	dB (A)	52		55		68	
	Heating	dB (A)	52		55		68	
Dimensions (W×D×H)	Indoor unit	mm	600x600x1756					
	Outdoor unit	mm	975x396x702		982x427x787		940x460x820	
Net weight	Indoor unit	kg	210					
	Outdoor unit	kg	55		82		110	
Water circulating pipe inlet/outlet, DHW	1" Male BSP							
Diameter of pipe	Liquid	Inch (mm)	1/4" (6.35)					
	Gas	Inch (mm)		1/2" (12.7)			5/8" (15.6)	

NOTE

«*» capacity and power input are specified under the following conditions:

Cooling Water temperature: +23°C/+18°C; Outdoor temperature: +35°C DB; +24°C WB

Heating Water temperature: +30°C/+35°C; Outdoor temperature: +7°C DB; +6°C WB

«**» capacity and power input are specified under the following conditions:

Cooling Water temperature: +12°C/+7°C; Outdoor temperature: +35°C DB; +24°C WB

Heating Water temperature: +40°C/+45°C; Outdoor temperature: +7°C DB; +6°C WB

TECHNICAL PARAMETERS UNITHERM 3 ALL-IN-ONE, 3 PHASE

			CH-HP12WTSIRM3	CH-HP14WTSIRM3	CH-HPWT16SIRM3
Capacity*	Cooling	kW	11.00	12.60	13.00
	Heating	kW	12.00	14.00	15.50
Power input*	Cooling	kW	2.50	3.41	3.60
	Heating	kW	2.40	2.98	3.44
EER *			4.40	3.70	3.60
COP *			5.00	4.70	4.51
Capacity*	Cooling	kW	10.65	11.24	11.52
	Heating	kW	12.29	14.44	16.13
Power input**	Cooling	kW	3.74	4.13	4.38
	Heating	kW	3.09	3.63	4.16
EER **			2.85	2.72	2.63
COP **			3.98	3.98	3.88
Refrigerant charge volume		kg	1.84	1.84	1.84
Power supply	-380-415V/50 Hz/3 Ph				
Sound pressure level	Cooling	dB (A)	62		
	Heating	dB (A)	58		
Dimensions (W×D×H)	Indoor unit	mm	600x600x1756		
	Outdoor unit	mm	940x460x820		
Net weight	Indoor unit	kg	210		
	Outdoor unit	kg	110		
Water circulating pipe inlet/outlet, DHW			1" Male BSP		
Diameter of pipe	Liquid	Inch (mm)	1/4" (6.35)		
	Gas	Inch (mm)	5/8" (15.6)		

NOTE

«*» capacity and power input are specified under the following conditions:

Cooling Water temperature: +23°C/+18°C; Outdoor temperature: +35°C DB; +24°C WB

Heating Water temperature: +30°C/+35°C; Outdoor temperature: +7°C DB; +6°C WB

«**» capacity and power input are specified under the following conditions:

Cooling Water temperature: +12°C/+7°C; Outdoor temperature: +35°C DB; +24°C WB

Heating Water temperature: +40°C/+45°C; Outdoor temperature: +7°C DB; +6°C WB

ELECTRICAL PARAMETERS UNITHERM 3 ALL-IN-ONE

	Power supply V/ Hz	Automatic switch (A)	The minimum cross-sectional area of the grounding wire (mm ²)	The minimum cross-sectional area of the power cable (mm ²)	
CH-HP6.0WTSIRK3(O)	-220-240V/50 Hz/1 Ph	16	15	15	
CH-HP6.0WTSIRK3(I)		20	6	6	
CH-HP8.0WTSIRK3(O)		25	4	4	
CH-HP8.0WTSIRK3(I)		40	6	6	
CH-HP10WTSIRK3(O)		25	4	4	
CH-HP10WTSIRK3(I)		40	6	6	
CH-HP12WTSIRK3(O)		32	6	6	
CH-HP12WTSIRK3(I)		40	6	6	
CH-HP14WTSIRK3(O)		40	6	6	
CH-HP14WTSIRK3(I)		40	6	6	
CH-HP16WTSIRK3(O)		40	6	6	
CH-HP16WTSIRK3(I)		40	6	6	
CH-HP12WTSIRM3(O)		-380-415V/50 Hz/3 Ph	16	2.5	2.5
CH-HP12WTSIRM3(I)			20	4	4
CH-HP14WTSIRM3(O)	16		2.5	2.5	
CH-HP14WTSIRM3(I)	20		4	4	
CH-HP16WTSIRM3(O)	16		2.5	2.5	
CH-HP16WTSIRM3(I)	20		4	4	

NOTES:

- If circuit breakers with leakage protection are used, the trip time should be less than 0.1 second and the leakage current should be 30 mA.
- The diameter of the power cables selected above is determined based on the assumption that the distance from the distribution box to the device is less than 75 m. If the cables are laid at a distance of 75 to 150 m, then the diameter of the power cable must be increased.
- The power source must meet the rated voltage of the device and must be connected to a separate electrical line.
- All electrical work must be performed by professional technicians in accordance with local codes and ordinances.
- Implement safety grounding. The grounding wire must be connected to a special grounding line in the building, the connection must be made by professional technicians.
- The switch and power cord specifications in the table above are based on the maximum power (maximum current) of the device.
- The power cable specifications in the table above refer to a stranded copper cable in a protective sheath (e.g. YJV cross-linked polyethylene insulated power cable) used at +40 °C and resistant to +90 °C (see IEC 60364-5-52). If the requirements are changed, the cables must be replaced according to the relevant standard.
- The switch specifications in the table above refer to the switch with an operating temperature of +40 °C. In the event of a change in conditions, they must be changed in accordance with the current national standard.
- An automatic switch must be installed in the power supply line. Automatic switch with disconnection of all poles. The opening distance between the contacts should be at least 3 mm.

PIPE CONNECTION OF UNITHERM 3 ALL-IN-ONE

ALL-IN-ONE	Diameter of pipe		Length B		Height A		Additional
	Gas	Liquid	Standard	Max	Standard	Max	
CH-HP6.0WTSIRK3	1/2"	1/4"	5 m	20 m	0 m	15 m	16 g/m
CH-HP8.0WTSIRK3	1/2"	1/4"	5 m	25 m	0 m	15 m	0 g/m
CH-HP10WTSIRK3	1/2"	1/4"	5 m	25 m	0 m	15 m	0 g/m
CH-HP12WTSIRK3	5/8"	1/4"	5 m	15 m *	0 m	15 m	0 g/m
CH-HP14WTSIRK3	5/8"	1/4"	5 m	15 m *	0 m	15 m	0 g/m
CH-HP16WTSIRK3	5/8"	1/4"	5 m	15 m *	0 m	15 m	0 g/m
CH-HP12WTSIRK3	5/8"	1/4"	5 m	15 m *	0 m	15 m	0 g/m
CH-HP14WTSIRK3	5/8"	1/4"	5 m	15 m *	0 m	15 m	0 g/m
CH-HP16WTSIRK3	5/8"	1/4"	5 m	15 m *	0 m	15 m	0 g/m

* Under certain conditions, the length can be increased to 25 m.

NOTES:

- Additional refrigerant charging is not required if the pipe length is less than 10m, if the pipe length is more than 10m, additional refrigerant charging is required according to the table. For example: if a 10 kW model is installed at a distance of 25 m, you should add $(25-10) \times 16 = 240$ g of refrigerant.
- Rated capacity is based on standard pipe length and maximum allowable length is based on working length. The grease intake loop should be installed every 5-7 meters if the external unit is located above the internal unit (hydro module).
- Each 90° bend is approximately equal to 0.5 meters of pipe length.

OVERALL DIMENSIONS OF OUTDOOR UNIT

CH-HP4.0WTSIRK3 (O), CH-HP6.0WTSIRK3 (O)

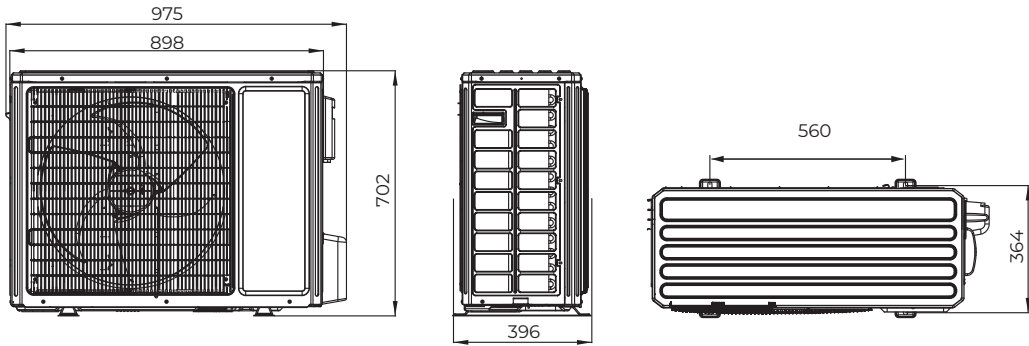

CH-HP8.0WTSIRK3 (O), CH-HP10WTSIRK3 (O)

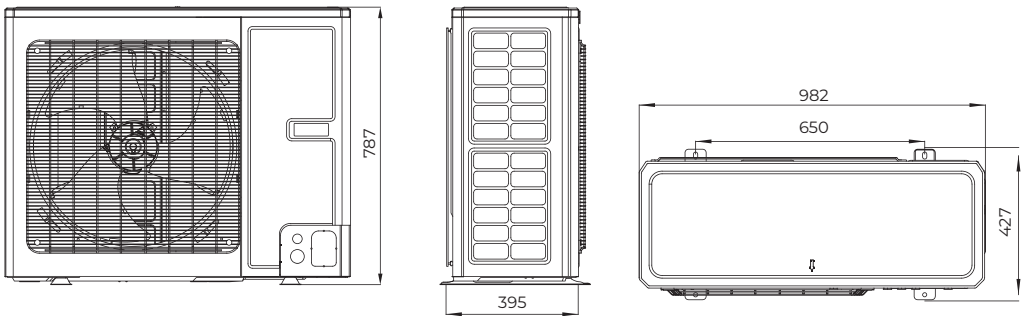

CH-HP12WTSIRM3(O), CH-HP14WTSIRM3(O), CH-HP16WTSIRM3(O),
CH-HP12WTSIRK3(O), CH-HP14WTSIRK3(O), CH-HP16WTSIRK3(O)

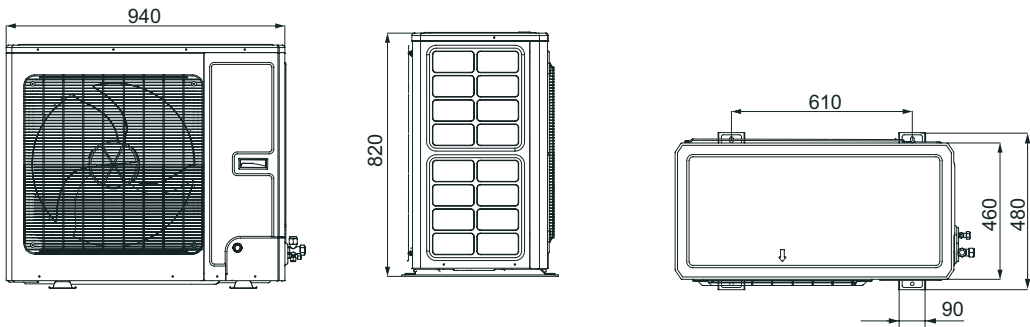

INVERTER MODULAR HEAT PUMPS

FOR HEATING AND COOLING

INVERTER



R32
FREON



-15°C ... +52°C



-20°C ... +40°C



OPTIONAL
XE73-25/G



INVERTER MODULAR HEAT PUMP

- ▶ Highly efficient modular heat pump with inverter control of compressors and fans;
- ▶ Low noise level and wide operating range;
- ▶ Modular design allows up to 16 heat pumps to be combined into a single system with a total heating/cooling capacity of up to 1040/960 kW;
- ▶ Remote control;
- ▶ High level of comfort and energy efficiency;
- ▶ Reliable protection systems;
- ▶ Balanced load for each compressor.



-20°C...
+52°C



+50°C
Max. water
temperature



Wide
Operation
Range



Self-diag-
nostics



Auto-pro-
tection



Golden Fin
Coating



DC
compressor



Timer



Copper
internal
grooves



Touch
Screen
Control



Intelligent
Defrosting



Intelligent
Control



BMS Control
Systems

Cooper&Hunter

CH-HP 35 UIMRM

Power supply:
K - ~220-240V/50 Hz/1 Ph
M - ~380-415V/50 Hz/3 Ph

Heat pump

Refrigerant type:
R - R32
N - R410A

Nominal capacity (kW)

Monoblock**U** - UNIVERSAL - heating + cooling**DC-inverter****TECHNICAL PARAMETERS**

		CH-HP35UIMRM	CH-HP65UIMRM	
Cooling capacity	kW	32	60	
Heating capacity	kW	35	65	
Rated cooling capacity	kW	11.7	20.8	
Rated heating capacity	kW	10.6	19.9	
Sound pressure level	dB (A)	62	68	
Power supply		-380-415V/50 Hz/3 Ph		
Operation control		The microcomputer implementing fully automatic control, displaying the operation state and giving an alarm		
Safety systems		High-pressure and low-pressure safety cut-out, high-discharge temperature cut-out, freeze-up control, overflow control, phase safety device, water flow safety control, pressure sensor cutout, temperature sensor cutout, four-way valve safety control, compressor overheating control		
Compressor	Type	Fully enclosed rotor-type compressor		
	Quantity	1	2	
	Starting mode	With variable frequency		
Water-side heat exchanger		High-efficiency shell-and-tube heat exchanger		
Water flow volume	m ³ /h	5.5	10.32	
Water resistance	kPa	80	55	
The highest bearing pressure	MPa	4.6		
Connection method		By external threads		
Piping inlet/outlet		1 1/4 Male BSP		
Air side	Air-side heat exchanger	High-efficiency finned coil heat exchanger		
	Rated power input of fan	W	750×2	
	Airflow volume	m ³ /h	2×0.63×10 ⁴	2×1.2×10 ⁴
Outline dimensions	Width	mm	1340	2200
	Depth	mm	845	965
	Height	mm	1605	1675
Net weight	kg	405	686	
Operating weight	kg	445	755	

ELECTRICAL PARAMETERS

	Power supply	Min. sectional area of the power cable (mm ²)			Capacity of the air switch (A)
		Live line	Neutral line	ground line	
CH-HP35UIMRM	~380-415V/50 Hz/3 Ph	6	6	6	32
CH-HP65UIMRM	~380-415V/50 Hz/3 Ph	16	16	16	63

OVERALL DIMENSIONS

Review

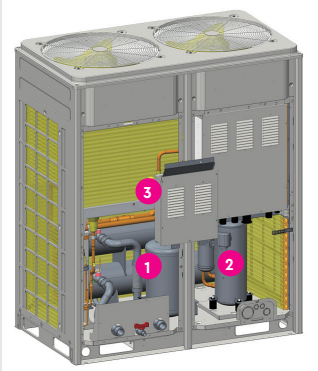

1. Vapor-liquid separator
2. Compressor
3. A shell-and-tube heat exchanger

CH-HP35UIMRM

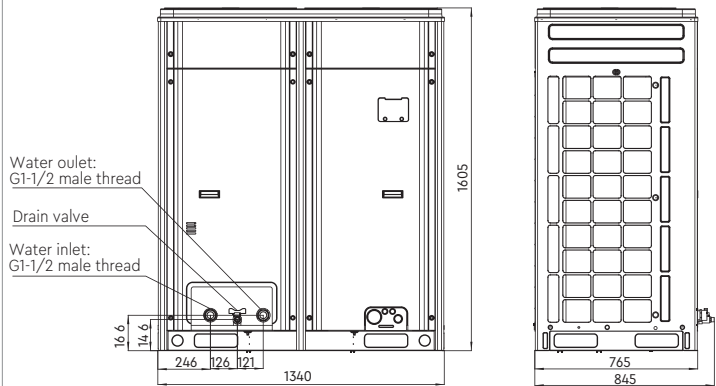
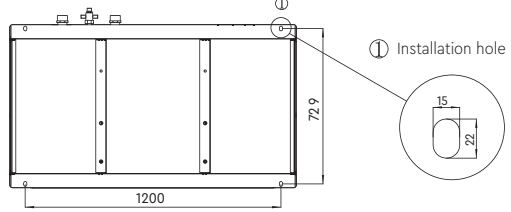

Review

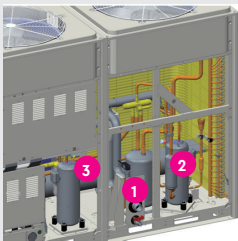

1. Two vapor-liquid separators
2. Two compressors
3. A shell-and-tube heat exchanger

CH-HP65UIMRM

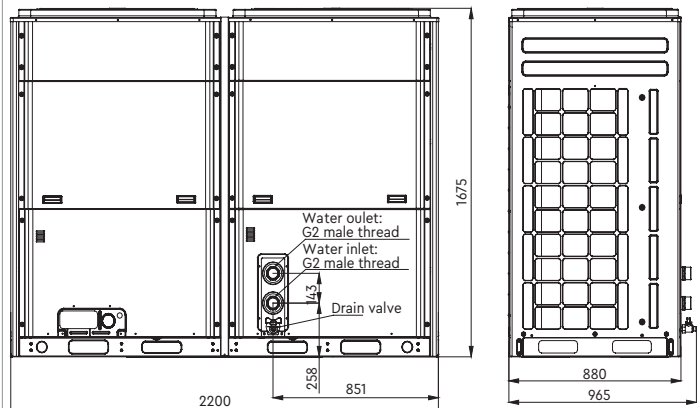
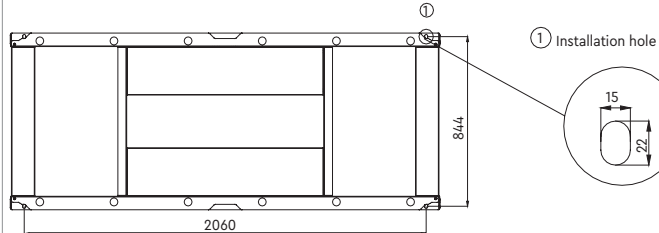



EVI TECHNOLOGY

EVI TECHNOLOGY

SERIES:

R290:
HYPERPOWER
ECOPOWER

EVI:
EVIPOWER PREMIUM R32
EVIPOWER INVERTER R32
EVIPOWER R410A

CENTRALISED CONTROL SYSTEM

Phase three

Phase two

Phase one



Central controller MXL 280 with 7" color display for controlling up to 16 heat pump units of the following series:

- Hyperpower
- Ecopower
- Premium
- Evipower Inverter
- Evipower (only for 42 and 84 kW models)

Note: It is not allowed to combine heat pumps of different series under the central control MXL280.

10-inch central
controller display

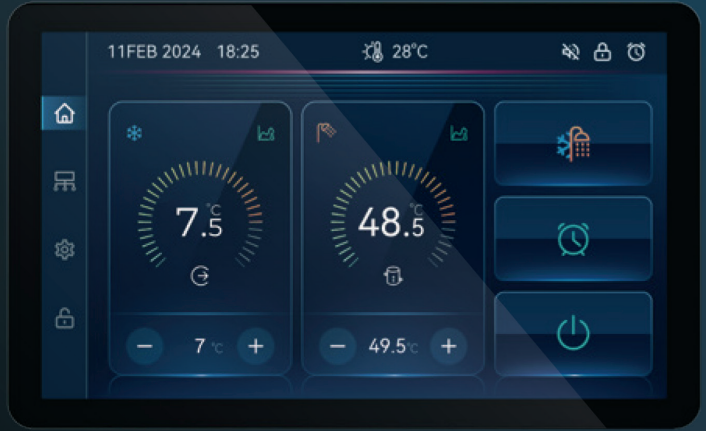

Temperature
timer



Up to 16 units in a
united row



Heat pump group
control



Real time graphic
indication of
parameters



Smart defrosting



Control input
signals



Work balancing



Sequential start of
heat pumps

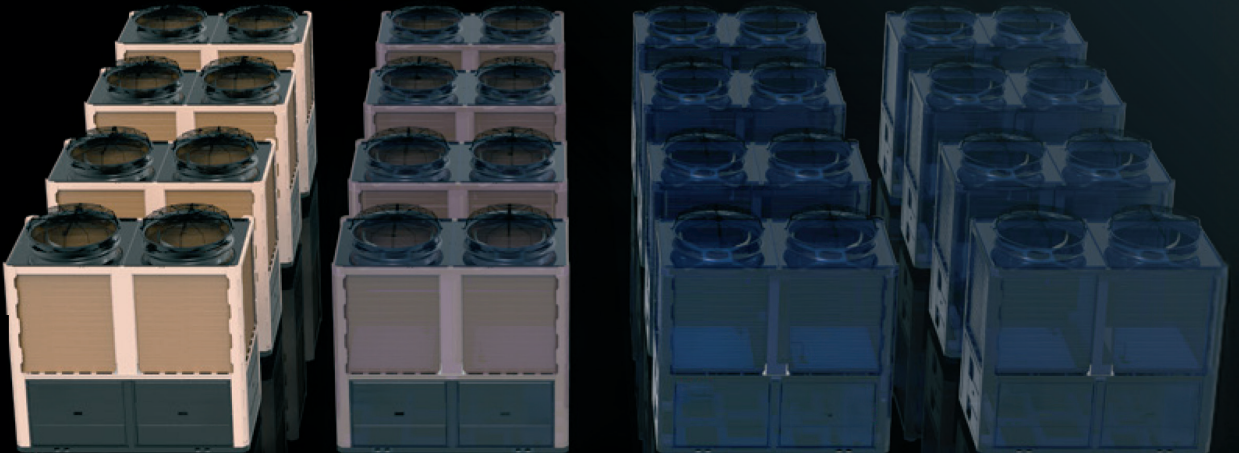

Central control ensures flexible connection of new heat pumps at different stages of construction.

STANDARD CONTROLLER

OPERATION AND FUNCTIONS OF THE TOUCH SCREEN

(EVIPOWER PREMIUM INVERTER, EVIPOWER INVERTER, EVIPOWER)

The latest 5-inch color display smart touch controller with a lot of different functions.

These include remote control functions such as BMS (Building Management System) and 4G MmN (Management and Monitoring Network).

Multilingual menu that allows you to specify and adjust temperature modes of operation: inlet water temperature, switching of operation modes, such as cooling/heating/hot water supply and mixed operation mode.

Accurate temperature control up to 0.5 °C. Indication of the temperature graph using the «Curve key» button. Various schedule timer functions, such as weekly time programming. In addition, the controller has standard functions that help the user himself, such as screen unlock, auto mode/mute. Powerful operating modes, failure log, color display calibration.

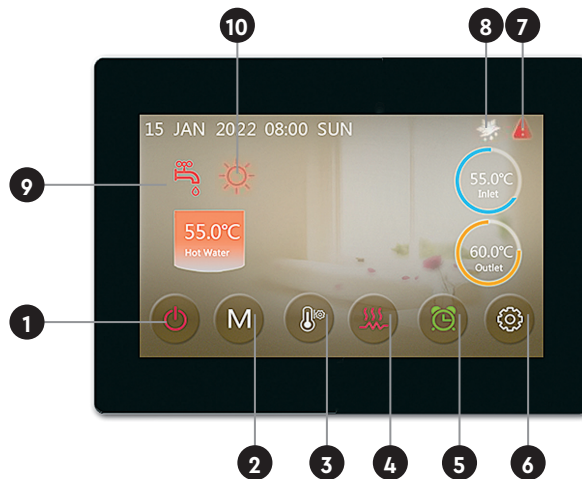

Function		
1	On/Off	Red means ON and gray means OFF
2	Mode	Can be selected one of five modes: DHW, heating mode, cooling mode, DHW+heating mode or DHW+cooling.
3	Temp. Setting	Temp. setting - setting the set temperature.
4	Fast heating	Fast heating - start of fast heating. This key will be displayed during heating.
5	Timer Setting	Timer settings - set a timer. White means off, while green means on.
6	Setup	Settings - Check device status, time, factory settings, temperature curve, timer settings and mute settings.
7	Fault	Fault - This icon flashes whenever an error occurs. After pressing this icon, the display will enter the error recording menu.
8	Defrost	Defrosting - the unit is in defrosting mode when this icon is displayed.
9	Hot Water Mode	Hot water mode - the unit is in DHW mode when this icon is displayed.
10	Cooling Mode	Cooling Mode - The device is in cooling mode when this icon is displayed.

Note: The controller may display temperature in °F or °C depending on the heat pump model.

OPERATION AND FUNCTIONS OF THE TOUCH SCREEN

(STANDARD FOR ECOPOWER SERIES)

Universal multifunctional control touch screen with many intelligent functions, such as weekly timer, building management system, 4G control and monitoring network, operation modes (cooling/heating/DHW), screen lock/unlock, temperature curve indication, fault log, calibration display, etc.

Display of the desired/current temperature up to 0.5 °C allows you to control the water temperature with high accuracy.

The possibility of combining different types of work modes:

1. Hot water (DHW)
2. Heating
3. Cooling
4. DHW + Heating
5. DHW + Cooling

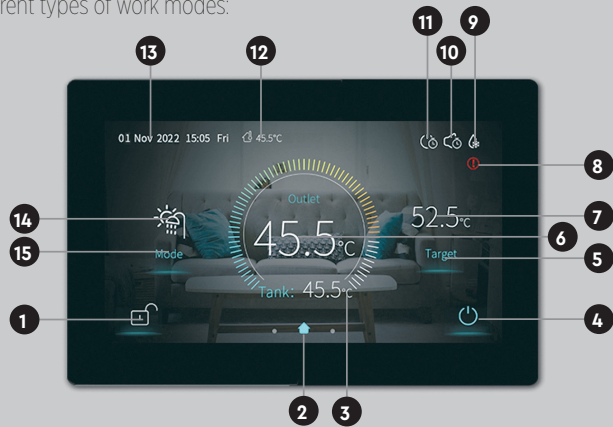

	Name	Function
1	Lock screen	Press this key to lock the screen. White means that the mode is not activated, blue means that the mode is activated.
2	HOME	Main menu page.
3	Water tank temperature	Indication of water tank temperature. The device is in DHW mode when this icon is displayed; Otherwise, this icon will not be displayed.
4	ON/OFF	Press this key to turn the device on or off. Blue means that the device is on, and white means that it is off.
5	Temperature setting	Press this key to set the desired temperature.
6	Outlet water/Room temperature	he leaving water temperature or room temperature is displayed. If H25=0 appears, the leaving water temperature will be displayed. If H25=1, room temperature will be displayed.
7	Target temperature	Setting the target (set) temperature of the device.
8	Fault	Malfunction (error). Fault indication. This icon blinks when an error occurs and a list of errors will appear on the display when this icon is pressed.
9	Defrosting icon	Will be displayed when the device is defrosting.
10	Silent timer	Quiet mode timer function. The indicator turns on only after the function is activated.
11	Timer	Enable/disable timer of the device. Displayed only after the function is activated.
12	Outdoor temperature	Indication of external temperature (ambient temperature).
13	Time setting	Setting of the time. System time display.
14	Current mode	Indication of the current mode.
15	Mode	Mode selection. Five modes can be selected by pressing the Mode button: DHW, heating, cooling, DHW + cooling, DHW + heating.

WATER KIT

HYDROMODULE FOR SERIES: HYPERPOWER
ECOPOWER
EVIPOWER PREMIUM INVERTER
EVIPOWER INVERTER



- ▶ Thanks to the technology of stepless electronic heating speed control, the most accurate temperature control is achieved.
- ▶ Reliable operation is ensured by GRUNDFOS DC inverter circulation pumps.
- ▶ The safety valve can automatically open and close according to the set working pressure.
- ▶ The well-thought-out combination of WATER KIT elements has made it possible to create one of the slimmest housings on the market.
- ▶ Unlike a traditional heat pump without a WATER KIT, a system with a WATER KIT allows you to automatically switch the heat pump between heating, DHW and cooling modes.
- ▶ The automatic feed valve maintains accurate pressure and ensures reliable operation.

TECHNICAL PARAMETERS

Unit		CH-HB10WK-W2	
Power Supply		V/Hz/Ph	-220-240/50/1
Capacity	Heating	kW	10
	Cooling	kW	8
Waterflow rate		m ³ /h	1.7
Heat exchanger pressure drop		kPa	22.0
HWS capacity rate		l/h	300
HWS temperature range		°C	5-60
Coonnection	Heat pump	inch	1" External thread
	heating	inch	1" External thread
	HWS	inch	3/4" External thread
Outside pressure	Heating	bar	3
	Water supply	bar	10
Heating circulation pump			DC
Circulation pump height		m	10.5
Water supply circulation pump			DC
Circulation pump height		m	7.5
Expansion tank		l	6
Heating element capacity		kW	3.0
Sound level pressure		dB(A)	35
Net/Gross weight		kg	37/52
Dimensions (L×W×H)	pack	mm	295×485×665
	w/o pack	mm	440×540×780

OVERALL DIMENSIONS

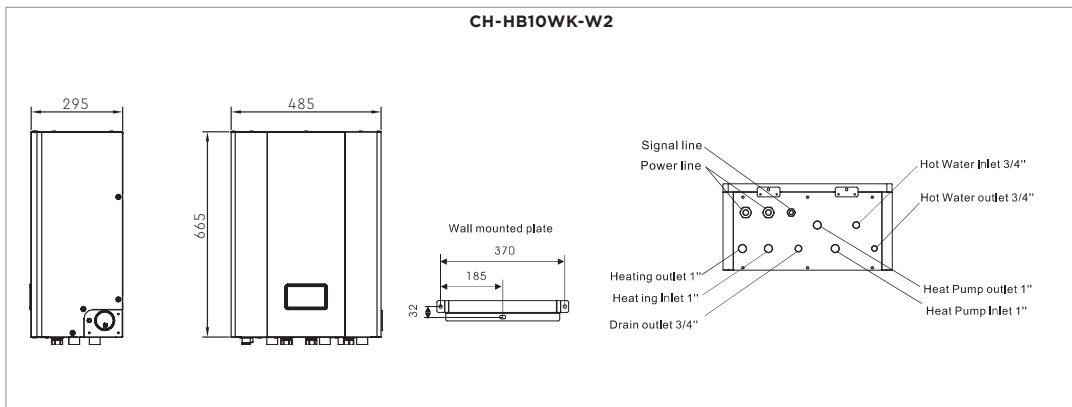

CENTRALIZED MANAGEMENT RS485 PROTOCOL



ECO POWER has a separate centralized control system through the RS485 port, the port is designed to control each individual device.

ELECTRONIC EXPANSION VALVE



Thanks to EEV, the system can instantly adjust the refrigerant flow to ensure stability.

ERGONOMIC DESIGN WITH HIDDEN FASTENING



The ECOPOWER series features a stylish and innovative casing design with no visible screws on the surface.

CIRCULATION WATER PUMP



The built-in circulation pump simplifies maintenance and service of the heat pump.



SWEP PLATE HEAT EXCHANGER

Thin air channels are formed between adjacent plates, through which heat exchange is carried out, which is more efficient than in traditional heat exchangers.



PRESSURE SENSOR

The pressure sensor can monitor the system pressure and send a signal to the main board to protect the device.



SG READY (SMART GRID READY)

SG Ready (smart grid ready) — heat pumps with the SG Ready label are standardised for connection to a smart power grid.



ASA MATERIAL

The body is made of ASA plastic, which provides high resistance to corrosion and atmospheric influences and ensures a long service life.



WARMLINK APPLICATION

The WarmLink app allows you to easily control EVI heat pumps via a local Wi-Fi network (standard IEEE 802.11b/g/n Wi-Fi network) or remotely via the Internet.

The WarmLink app allows you to:

- monitor the status of the heat pump, including current water flow, water temperature, current operating mode, etc.
- set/change the status of the heat pump, for example: on/off settings, set water temperature, mode settings, timer settings, etc.
- Get more detailed information about water temperature trends via the temperature curve.
- Get information about any heat pump malfunctions.
- Share access with service specialists remotely for any problems detected in the background, without directly contacting the service department.

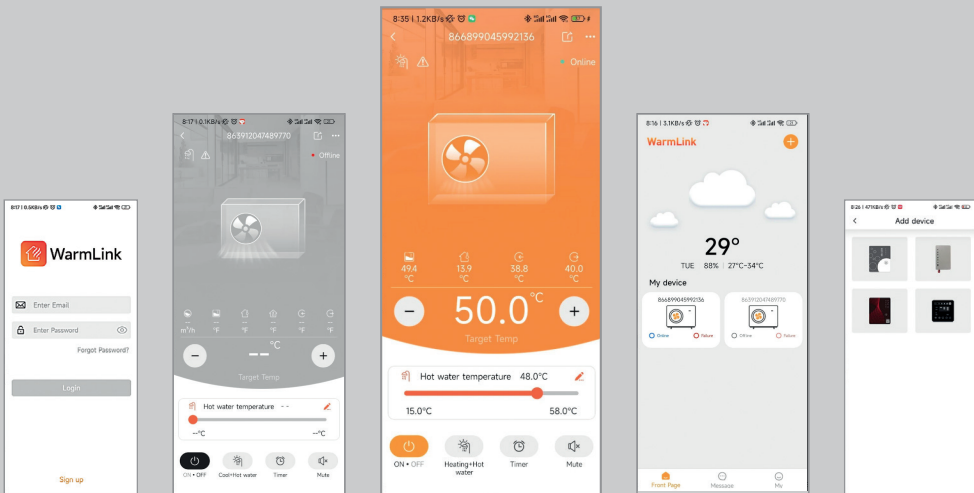

WEB PLATFORM

Central remote control can be implemented using DTU or Wi-Fi, which effectively saves on maintenance/system status notification costs.

Error messages are displayed on the computer of the responsible personnel. When an error is detected on the screen, the service department/C&H representative must be notified.

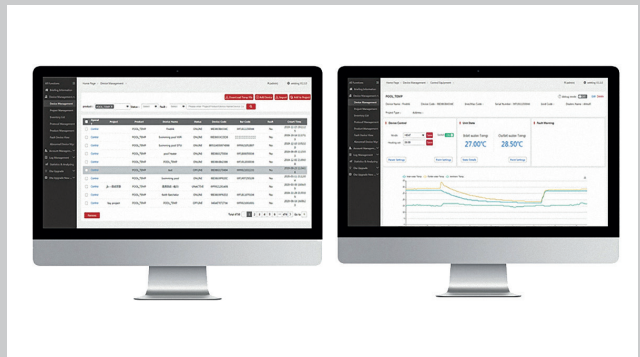

- 4G + WI-FI MODULE (NEW)

NEW DTU module (4G+WiFi) *for Hyperpower and Evipower series manufactured in 2025.

The new DTU module allows you to choose one of two remote control methods: via a 4G cellular network or via WiFi. The module comes with an antenna that can be placed outside the unit to improve signal quality.

The new DTU module is designed to work with the following models:



Adjustable Temperature

WiFi

Heating & Hot Water

Hot Water

Heating

Cooling

Cooling & Hot Water

Silent

Timers

Unit Status

History Data Display

- 4G MODULE (FACTORY CONFIGURATION)

Intelligent and remote control of the device provides users with many conveniences. Temperature control, mode switching and timer settings can be performed on your smartphone via 4G mobile internet. In addition, you can check power consumption and fault records at any time and anywhere, again using 4G mobile internet.



- WI-FI MODULE (OPTIONAL)



HYPER POWER INVERTER SERIES

FOR HEATING OR
COOLING AND DHW



0°C ... +43°C



-30°C ... +43°C



R290
FREON

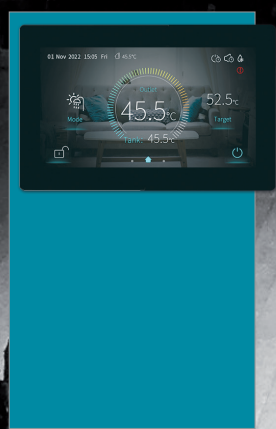

HYPER POWER INVERTER

- ▶ Maximum coolant outlet temperature +75°C, only due to the refrigerant.
- ▶ Inverter control technology with a DC motor.
- ▶ Remote controller with a second-generation 5-inch touch screen.
- ▶ Minimum noise level 40 dB(A).
- ▶ Support for 4G or Wi-Fi MMN (Management and Monitoring Network).
- ▶ Weather-dependent mode.
- ▶ Integration with the IoT cloud platform.
- ▶ SG-Ready.



-30°C... +43°C



Max. water temperature +75°C



Energy Efficiency A+++



Self-diagnostics



Auto-protection



Anti-corrosive Coating



DC compressor



Timer



Wired Controller



Intelligent Defrosting



Intelligent Control



4G



BMS Control Systems



EXCEPTIONAL EFFICIENCY FOR YOUR HOME: TECHNOLOGIES OF THE FUTURE



SG Ready (short for 'Smart Grid Ready') is a term used to label devices, usually heat pumps, that have a special interface for integration with smart grids.

This label, introduced by the German Heat Pump Association (Bundesverband Wärmepumpe, BWP), indicates that the device can receive external signals and respond to them by automatically adjusting its operation.

Key features and benefits of SG Ready:

- Energy consumption optimisation;
- Integration with solar systems (PV Ready);
- Response to signals from the grid;
- Cost reduction;
- Promotion of grid stability;

Thus, SG Ready is a standard that makes devices such as heat pumps 'smarter' by allowing them to interact with modern energy infrastructure for greater efficiency, savings and stability.

55 °C



35 °C



This product has the highest energy efficiency rating of A+++ and an impressive seasonal coefficient of performance (SCOP) of over 5.0. Its excellent performance and exceptional efficiency are achieved through carefully selected components and innovative solutions specially adapted to European conditions. This includes a Grundfos circulation pump; a Panasonic compressor specially designed to work with R290 (propane) refrigerant; a built-in automatic air release valve and other elements that guarantee reliability and durability. These are complemented by ultra-efficient fans that minimise energy consumption, as well as finned heat exchangers with a unique design based on advanced airflow modelling for maximum heat transfer. This solution provides comfort and significant savings.

PROGRESSIVE DESIGN FOR SPECIAL NOISE AND VIBRATION REQUIREMENTS



20 dB(A)
Leaf noise



30 dB(A)
Whisper



40 dB(A)
Hyper Power
Inverter Series



50 dB(A)
Refrigerator



70 dB(A)
Car

- Lightweight and streamlined grille with increased cross-section and low-resistance air diffuser;
- Toothed fan blades designed using CFD modelling for greater airflow;
- Panasonic DC motor;



Improved design and better compactness: a built-in DC inverter drive board controls the fan and compressor. The casing is made of composite materials and equipped with rubber shock-absorbing feet.

OPERATING RANGE IN HEATING MODE

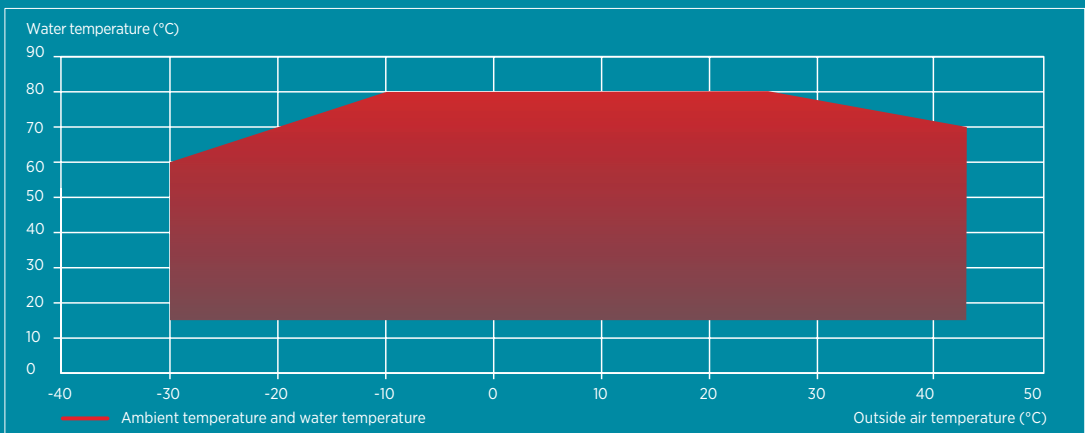

TECHNICAL PARAMETERS

			CH-HP15UIIMPZM-H	CH-HP22UIIMPZM-H
Heating Capacity Range		kW	4.3-18.7	4.5-23.4
Heating Power Input Range		kW	0.7-4.5	0.9-5.5
Cooling Capacity Range		kW	3.8-13.8	5.0-20.0
Cooling Power Input Range		kW	0.8-5.5	1.0-6.5
Max. power input		kW	8	8.5
Max. current input		A	12	15
Power supply		V/ph/Hz	380-415/3/50	
Compressor quantity		-	1	1
Compressor Type		-	Rotary	
Fan Type		-	DC	
Rated air flow		m ³ /h	5000	6000
Sound pressure level (1m)		dB(A)	40	42
Condenser Type		-	Braze plate heat exchanger	
Water flow		m ³ /h	2.06	2.92
Water Pressure Drop		kPa	22	52
Circulation Pump Water Head		m	3	5
Piping connection		inch	1" Female	
Refrigerant charge volume		kg	1.2	1.7
Max outlet heating water temperature		°C	75	
Operating ambient temp. range (heating)		°C	-30-43	
Operating ambient temp. range (DHW)		°C	-30-43	
Operating ambient temp. range (cooling)		°C	10-43	
Weight	Net	kg	214	275
	Gross	kg	224	293
Dimensions (W×D×H)	Unit	mm	1438×544×1105	1437×545×1524
	Packing	mm	1588×623×1206	1588×623×1622
Seasonal heating energy efficiency class at 35°C / 55°C		-	A+++/A+++	
Heating Capacity	7°C / 35°C *	kW	11.8	16.89
	7°C / 55°C*		11.9	17.1
	-7°C / 35°C**		10.64	15.34
	-7°C / 55°C**		10.81	15.23
Energy efficiency	COP 7°C / 35°C*	W/W	4.83	4.88
	COP 7°C / 55°C*		3.28	3.38
	COP -7°C / 35°C**		2.96	3.32
	COP -7°C / 55°C**		2.2	2.56
	SCOP 7°C / 35°C**		4.83	5.15
	SCOP 7°C / 55°C**		3.86	4.01

*Heating capacity and energy efficiency evaluation according to EN 14511-2.

**Heating capacity and energy efficiency evaluation according to EN 14825 under part load conditions and in a moderate climate.

OVERALL DIMENSIONS

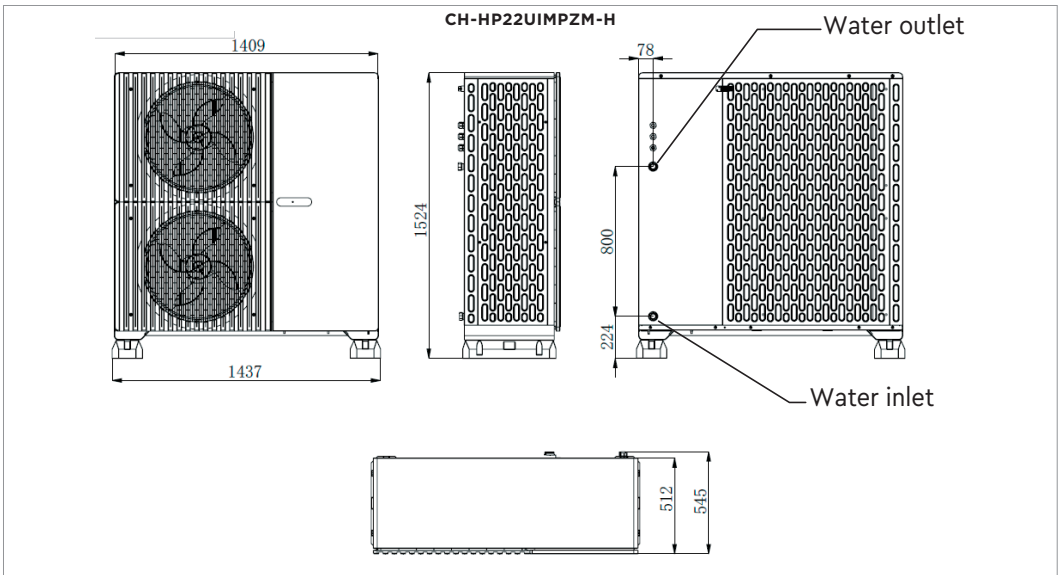
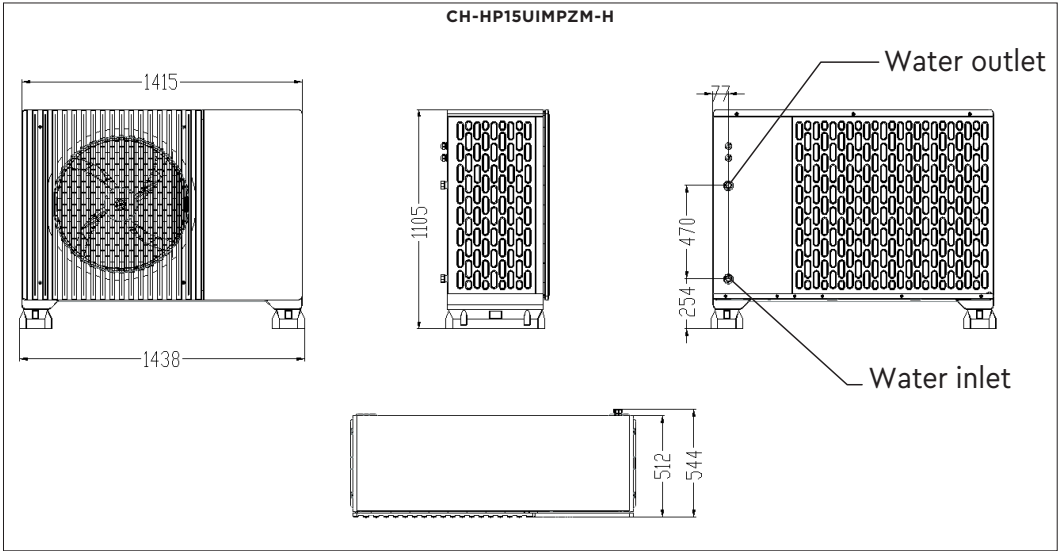

ECOPOWER SERIES

FOR HEATING OR
COOLING AND DHW

 R290
FREON

+75°C

 +15°C ... +43°C

 -25°C ... +43°C





ECOPOWER

- ▶ Maximum water heating temperature up to 75°C.
- ▶ DC inverter technology.
- ▶ Minimum sound pressure level 42 dB.
- ▶ LCD SMART Display with a new generation 5-inch touch screen.
- ▶ 4G MMN (Management and Monitoring Network) module.
- ▶ Weather-dependent mode.
- ▶ IoT cloud platform.
- ▶ Wi-Fi (optional).
- ▶ Cascade control of up to 16 heat pumps via the MXL 280 central controller.



-25°C...+43°C



Max. water temperature



Energy Efficiency



Self-diagnostics



Auto-protection



Anti-corrosive Coating



DC compressor



Timer



Wired Controller



Intelligent Defrosting



Intelligent Control



4G



BMS Control Systems



ECOPOWER HEAT PUMPS:

Power, Efficiency, Silence

The **ECOPOWER** series of heat pumps has been designed to meet the highest standards of modern climate control technology. It combines three key advantages: high efficiency, stable operation and extremely low noise levels, making it the ideal solution for your home.

One of the main features of the **ECOPOWER** series is the use of environmentally friendly **R290** refrigerant in combination with advanced inverter technology. This unique combination has made it possible to achieve an exceptional A++ energy efficiency rating even when heating the coolant to 55°C, which is an important indicator for heating systems.

Thanks to this high level of efficiency, using **ECOPOWER** heat pumps can significantly reduce your electricity bills. This not only reduces your costs, but also makes a significant contribution to protecting the environment.



R290 FREON

For Cooper&Hunter, combating climate change is a priority. To effectively reduce CO2 emissions into the atmosphere and curb global warming, we have switched to using the innovative and environmentally friendly refrigerant **R290** (propane).

Freon R290 is recognised by experts as one of the most promising refrigerants in the industry. It has an extremely low global warming potential (GWP), making it a key tool for significantly reducing carbon dioxide emissions into the Earth's atmosphere. The use of this refrigerant in our systems allows us not only to maintain high equipment efficiency, but also to make an important contribution to preserving our planet for future generations.

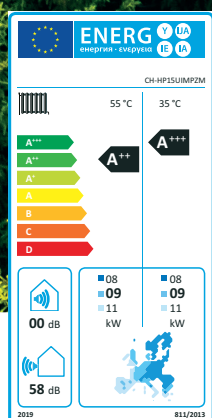

INNOVATIONS FOR YOUR COMFORT AND PEACE OF MIND

Cooper&Hunter is dedicated to creating ultra-quiet, highly efficient and environmentally friendly heat pumps. The **ECOPOWER** series is the result of innovative technologies that significantly reduce noise levels. Each product undergoes multi-level testing and optimisation, ensuring the highest quality and comfort.

Nominal sound pressure level: 42-48 dB(A)

- Low-noise compressor and motor
- Optimised airflow and fan design
- Anti-vibration compressor base



20dB(A)
The rustling
of leaves



30dB(A)
Whisper



42-48 dB(A)
SERIES ECOPOWER



50dB(A)
Refrigerator



70dB(A)
Car



TECHNICAL PARAMETERS

			CH-HP09UIMPZK	CH-HP15UIMPZK	CH-HP15UIMPZM	CH-HP22UIMPZM	CH-HP28UIMPZM	
Heating Capacity Range		kW	3.10-8.90	5.40-14.95	5.40-14.95	8.00-22.00	8.18-28.0	
Heating Power Input Range		kW	0.65-2.10	1.05-3.85	1.05-3.85	1.60-6.90	2.29-8.27	
Cooling Capacity Range		kW	1.20-5.72	3.60-10.50	3.60-10.50	4.20-15.00	5.03-18.5	
Cooling Power Input Range		kW	0.65-2.40	1.12-4.47	1.12-4.47	1.80-7.30	2.49-9.24	
Max. power input		kW	3	5.3	5.3	9	12.6	
Max. current input		A	13.5	24.5	10.5	15.8	17	
Power supply		V/ph/Hz	220-240/1/50			380-415/3/50		
Sound pressure level (1m)		dB(A)	42	43	44	47	53	
Sound power		dB(A)	57	57	58	62	68	
Compressor quantity		/					1	
Fan quantity		/	1			2		
Fan Type		/					DC	
Piping connection		inch					1/2 Female	
Refrigerant charge volume R290		kg	0.5	0.85		1.3	1.8	
Water flow		m ³ /h	1	1.7		2.9	3.4	
Water Pressure Drop		kPa	18.3	29.5		42.2	50	
Circulation Pump Water Head		m	7.5	7.5		12.5	12.5	
Weight	Net	kg	80	160		202	202	
	Gross	kg	122	170		223	223	
Dimensions (W*D*H)	Unit	mm	1170x400x790	1290x460x930		1250x505x1330		
	Packing	mm	1300x485x940	1420x540x1080		1380x570x1480		
Seasonal heating energy efficiency class at 35°C / 55°C		-					A+++/A+++	
Heating Capacity	7°C / 35°C *	kW	5.83	10.92	10	15.73	19.67	
	7°C / 55°C*		6.28	10.36	10.32	17.03	19.96	
	-7°C / 35°C**		4.35	8.37	8.22	11.11	17.48	
	-7°C / 55°C**		4.17	7.98	8.17	10.92	15.24	
Energy efficiency	COP 7°C / 35°C *	W/W	4.79	5.26	4.99	3.99	4.42	
	COP 7°C / 55°C*		3.07	3.07	3.3	3.56	2.61	
	COP -7°C / 35°C**		3.23	3.2	3.17	3.23	2.9	
	COP -7°C / 55°C**		2.32	2.38	2.58	2.34	2.31	
	SCOP 7°C / 35°C**		5	4.9	4.92	4.91	4.71	
	SCOP 7°C / 55°C**		3.71	3.76	3.78	3.7	3.49	

*Heating capacity and energy efficiency evaluation according to EN 14511-2.

**Heating capacity and energy efficiency evaluation according to EN 14825 under part load conditions and in a moderate climate.

OVERALL DIMENSIONS

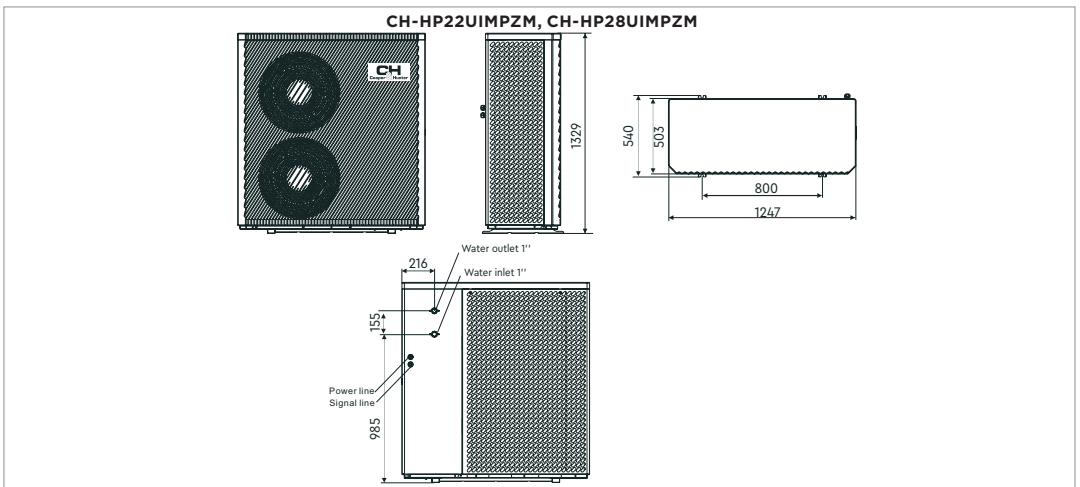
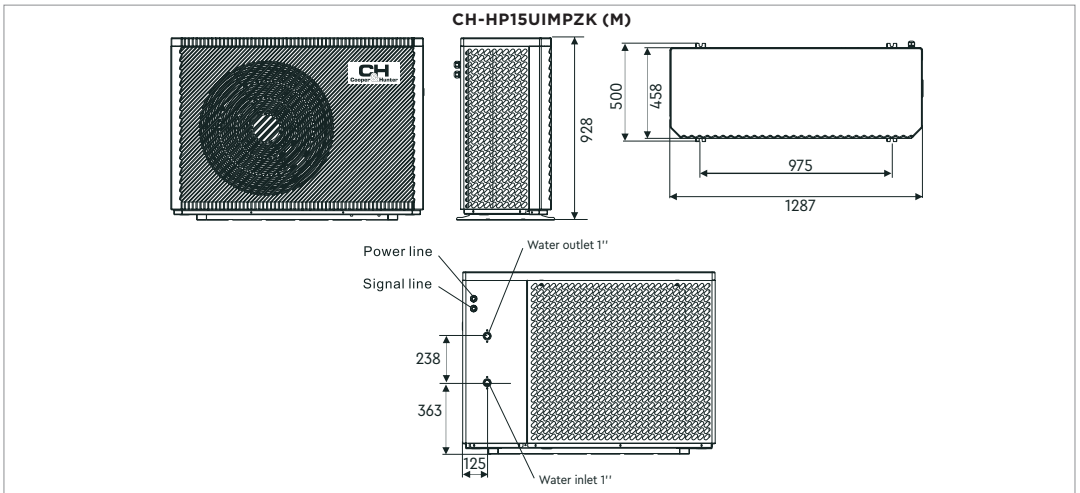
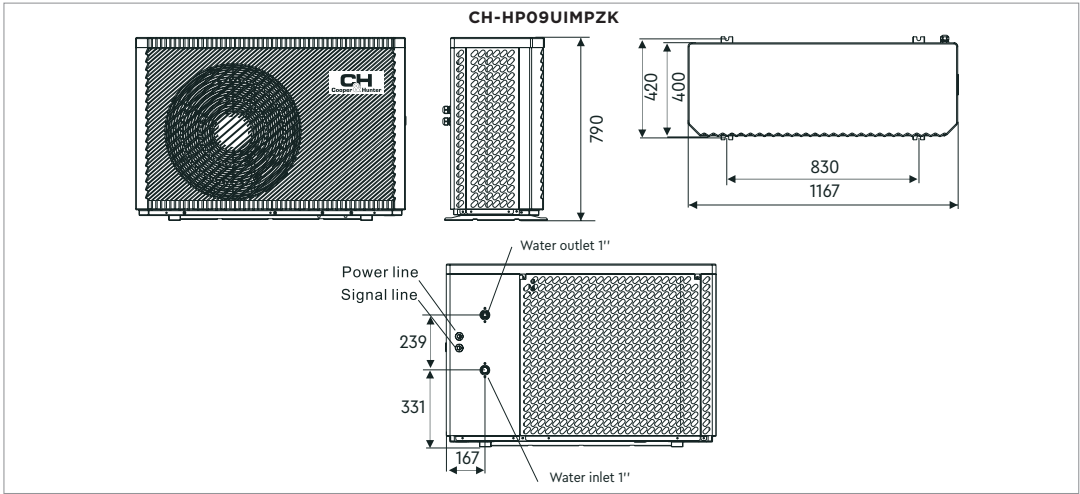

TECHNICAL PARAMETERS

			CH-HP44UIMZM	CH-HP75UIMZM	CH-HP110UIMPZM*
Heating Capacity Range		kW	13.63-50.00	20.45-75.0	30.0-110.0
Heating Power Input Range		kW	4.36-16.00	6.54-24.00	8.57-32.70
Cooling Capacity Range		kW	9.27-34.00	14.10-50.00	27.0-88.0
Cooling Power Input Range		kW	3.91-14.35	5.95-21.82	8.64-32.30
Max. power input		kW	24	36	50
Max. current input		A	30	45	82
Power supply		V/ph/Hz	380-415/3/50		
Sound pressure level (1m)		dB(A)	62	68	60
Sound power		dB(A)	77	83	78
Compressor quantity		/	2	2	2
Fan quantity		/	1	2	2
Fan Type		/	DC		
Piping connection		inch	1.5" Female	DN50	DN50
Refrigerant charge volume R290		kg	1.5*2	2.4*2	4.7*2
Water flow		m ³ /h	5.85	8.5	12
Water Pressure Drop		kPa	20	25	60
Circulation Pump Water Head		m	/	/	12
Weight	Net	kg	363	733	1100
	Gross	kg	456	833	1200
Dimensions (W×D×H)	Unit	mm	1198×980×1816	1965×1060×2070	2300×1018×2430
	Packing	mm	1320×1100×2060	2055×1060×2070	2300×1118×2530
Seasonal heating energy efficiency class at 35°C / 55°C		-	A+++/A+++		
Heating Capacity	7°C / 35°C *	kW	34.47	50.20	
	7°C / 55°C*		25.76	50.13	
	-7°C / 35°C**		22.61	44.07	
	-7°C / 55°C**		22.58	44.24	
Energy efficiency	COP 7°C / 35°C *	W/W	4.22	4.48	-
	COP 7°C / 55°C*		1.95	3.18	
	COP -7°C / 35°C**		3.01	2.91	
	COP -7°C / 55°C**		2.07	2.21	
	SCOP 7°C / 35°C**		4.52	4.61	
	SCOP 7°C / 55°C**		3.26	3.71	

*Heating capacity and energy efficiency evaluation according to EN 14511-2.

**Heating capacity and energy efficiency evaluation according to EN 14825 under part load conditions and in a moderate climate.

*** CH-HP110UIMPZM - New product. At the time of the catalog publication, certification data for the heat pump was not available.

OVERALL DIMENSIONS

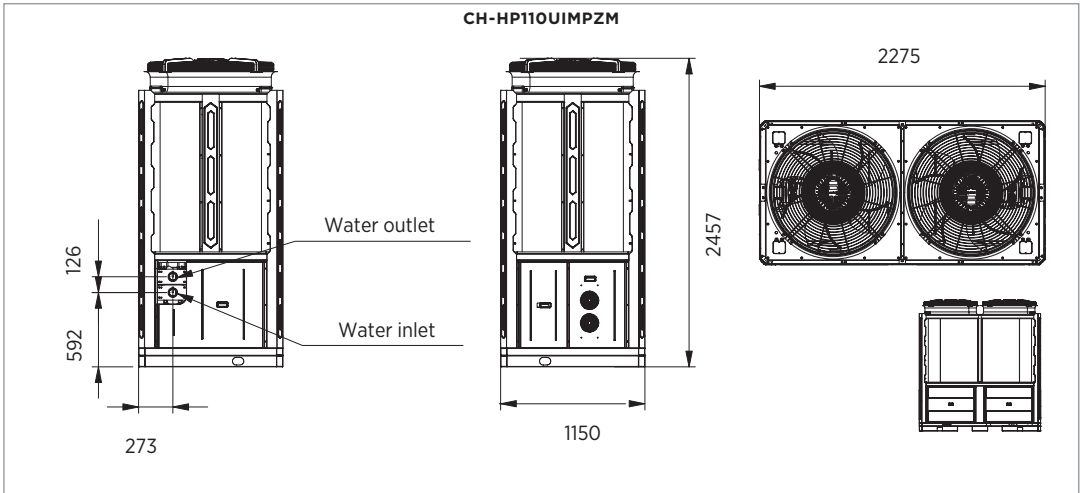
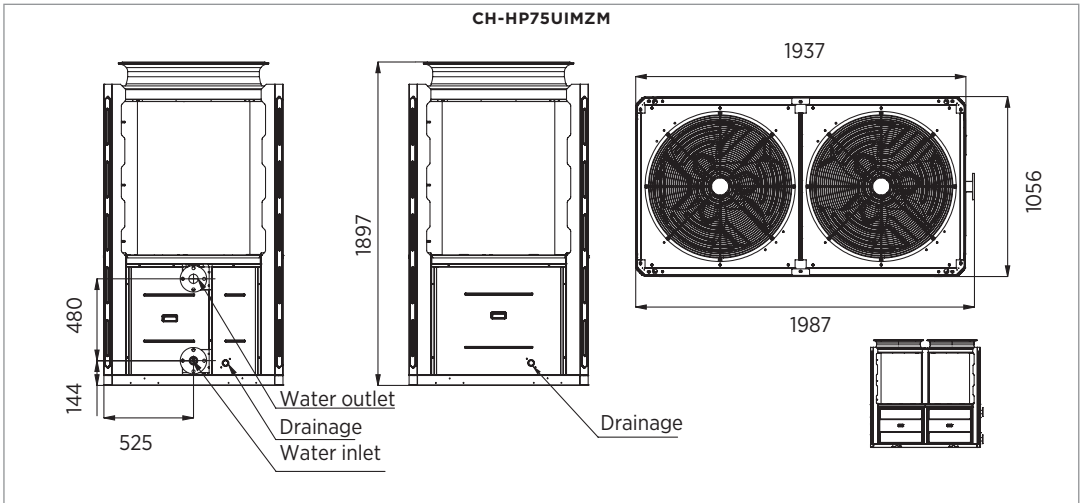
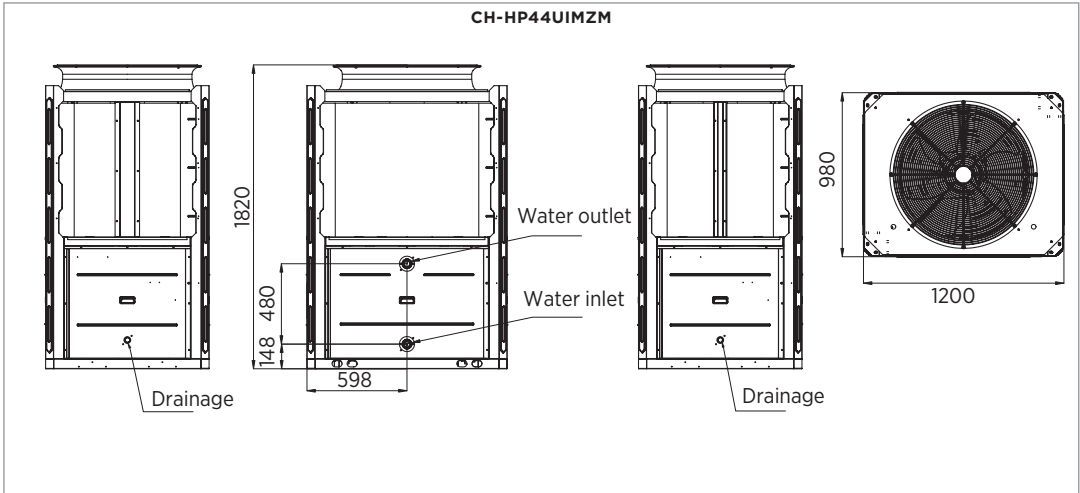

EVIPOWER PREMIUM INVERTER SERIES

FOR HEATING OR
COOLING AND DHW

+60°C

 +15°C ... +43°C

 -25°C ... +43°C

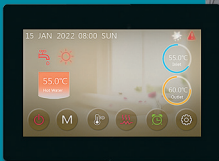

EVIPOWER PREMIUM INVERTER

- ▶ Five operating modes: heating, cooling, DHW, heating + DHW, cooling + DHW;
- ▶ Maximum water heating temperature up to 60°C.
- ▶ Operating conditions: up to -25°C ambient temperature for heating; up to +43°C for cooling;
- ▶ EVI DC-inverter technology;
- ▶ 4G MMN module (Management and Monitoring Network);
- ▶ Smart defrosting;
- ▶ Silent mode;
- ▶ Cascade control of up to 16 heat pumps via the MXL280 central controller.



-25°C... +43°C



Max. water temperature



Energy Efficiency



Self-diagnostics



Auto-protection



Anti-corrosive Coating



EVI Compressor



Timer



Wired Controller



Intelligent Defrosting



Intelligent Control



4G



BMS Control Systems

TECHNICAL PARAMETERS

			CH-HP08UIMPRK-P	CH-HP12UIMPRM-P	CH-HP23UIMPRM-P
Heating Capacity Range		kW	2.30-8.20	3.80-12.50	7.00-23.00
Heating Power Input Range		kW	0.50-1.84	0.80-2.95	1.27-5.20
Cooling Capacity Range		kW	1.56-6.00	2.20-10.00	6.30-18.40
Cooling Power Input Range		kW	0.63-2.36	1.10-3.80	1.63-7.05
Max. power input		kW	2.90	4.95	8.30
Max. current input		A	13.0	8.0	15.0
Power supply		V/ph/Hz	220-240/1/50	380-415/3/50	
Water flow		m ³ /h	1.0	1.7	2.9
Water Pressure Drop		kPa	20	30	45
Circulation Pump Water Head		m	7.5	5.5	10.2
Piping connection		inch	1" Female		
Refrigerant charge volume R32		kg	1.1	1.8	2.0
Sound pressure level (1m)		dB(A)	37-48	39-52	42-54
Fan quantity		/	1	1	2
Fan speed		rpm	600		
Weight	Net	kg	90	132	208
	Gross	kg	113	152	216
Dimensions (W×D×H)	Unit	mm	1170x400x790	1290x460x930	1250x505x1330
	Packing	mm	1300x485x940	1420x540x1080	1380x570x1480
Seasonal heating energy efficiency class at 35°C / 55°C		-	A+++/A++		
Heating Capacity	7°C / 35°C*	kW	5.99	9.81	16.61
	7°C / 55°C*		5.13	8.97	15.15
	-7°C ext / 35°C**		3.28	7.72	11.27
	-7°C ext / 55°C**		2.2	8.41	12.77
Energy efficiency	COP 7°C / 35°C*	W/W	4.97	5	4.9
	COP 7°C / 55°C*		2.74	3.01	3.14
	COP -7°C ext / 35°C**		4.68	3.39	3.32
	COP -7°C ext / 55°C**		5	2.32	2.26
	SCOP 7°C / 35°C**		4.75	4.61	4.57
	SCOP 7°C / 55°C**		3.33	3.32	3.34

*Heating capacity and energy efficiency evaluation according to EN 14511-2.

**Heating capacity and energy efficiency evaluation according to EN 14825 under part load conditions and in a moderate climate.

OVERALL DIMENSIONS

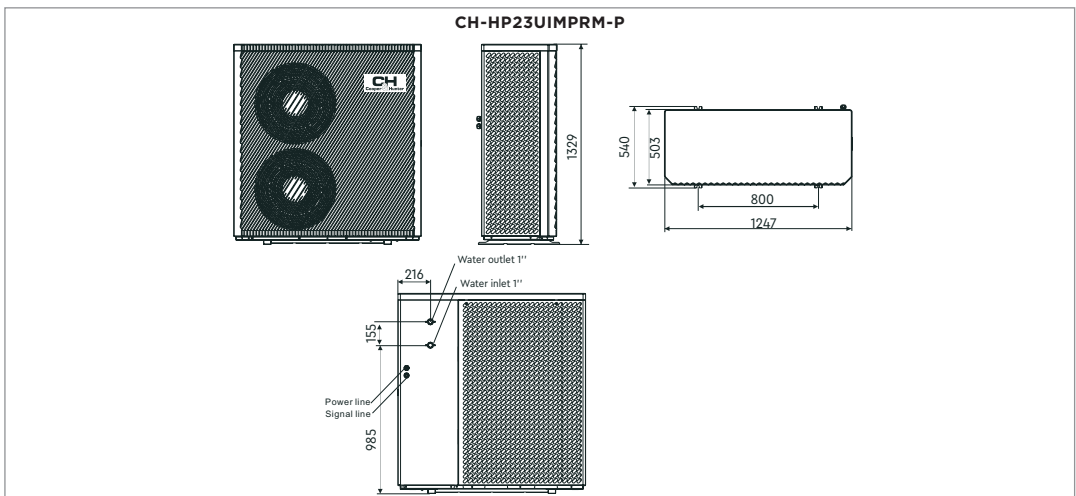
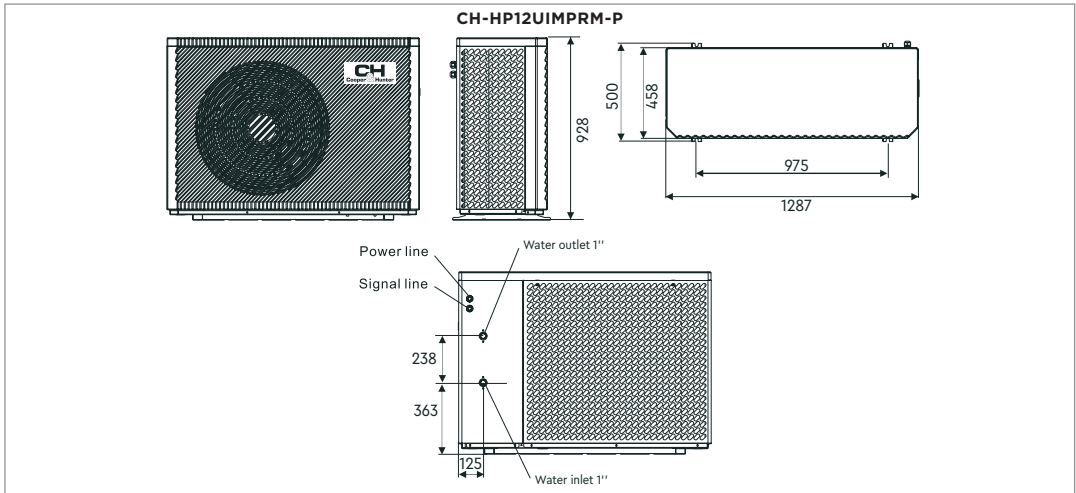
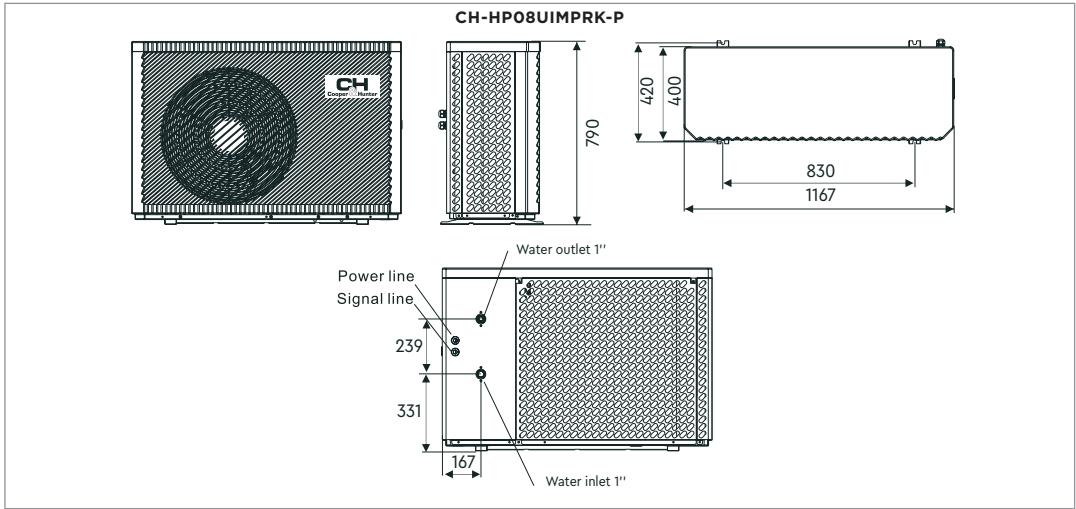

EVIPOWER INVERTER SERIES

FOR HEATING OR
COOLING AND DHW

- ▶ Maximum water heating temperature up to 60°C.
- ▶ Use of
- ▶ EVI DC inverter technology.
- ▶ New generation 5-inch touchscreen LCD SMART Display.
- ▶ 4G MMN (Management and Monitoring Network) module.
- ▶ Weather-dependent mode function.
- ▶ Integration with the IoT cloud platform.
- ▶ Cascade control of up to 16 heat pumps via the MXL280 central controller.



-25°C...+43°C



Max. water temperature



Energy Efficiency



Self-diagnostics



Auto-protection



Anti-corrosive Coating



EVI Compressor



Timer



Wired Controller



Intelligent Defrosting



Intelligent Control



4G



BMS Control Systems

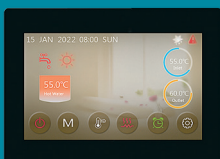

☃ +15°C ... +43°C

☀ -25°C ... +43°C



TECHNICAL PARAMETERS

		CH-HP08UIMPRK	CH-HP12UIMPRM	CH-HP20UIMPRM
Cooling capacity	kW	1.98-6.10	3.22-11.30	5.50-15.50
Heating capacity	kW	2.29-8.25	4.70-12.50	7.00-20.50
Power input for cooling	kW	0.70-2.22	1.27-4.64	1.50-6.00
Power input for heating	kW	0.63-1.81	1.08-3.44	1.50-6.00
SCOP	W/W	4.47	4.04	4.32
Max. power input	kW	2.9	4.64	7.20
Max. current input	A	13.0	7.6	12.0
Power supply		-220-240V/50 Hz/1 Ph		-380-415V/50 Hz/3 Ph
Compressor type			Rotary	
Circulation pump			DC	
Number of fans			1	2
Sound pressure level (1m)	dB(A)	37-54	42-55	44-58
Piping inlet/outlet	inch		1" Female	1 1/4" Female
Water flow	m ³ /h	1	1.7	2.9
Heat exchanger resistance	kPa	28	35	65
Circulation pump pressure	m	5.5	5.5	12.5
Refrigerant charge volume	kg	1,3	1,6	2
Dimensions (W×D×H)	mm	1002×490×805	953×460×915	997×437×1315
Net weight	kg	90	100	155

Cooling: external temperature DB / WB 35 °C / 24 °C outlet water temperature 7 °C, inlet water temperature 12 °C.
 * Heating: external temperature DB / WB 7 °C / 6 °C outlet water temperature 35 °C, inlet water temperature 30 °C.

OVERALL DIMENSIONS

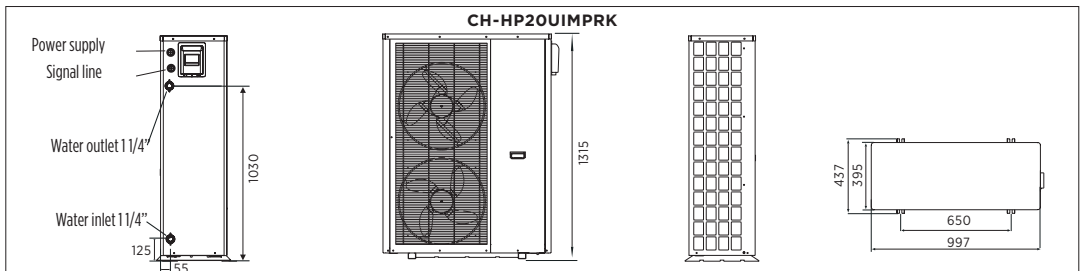
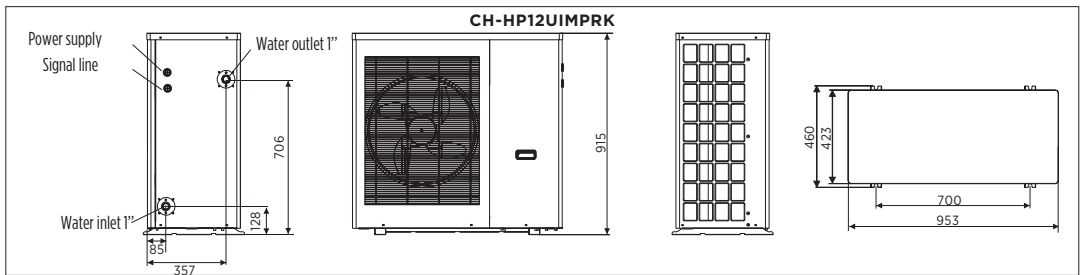
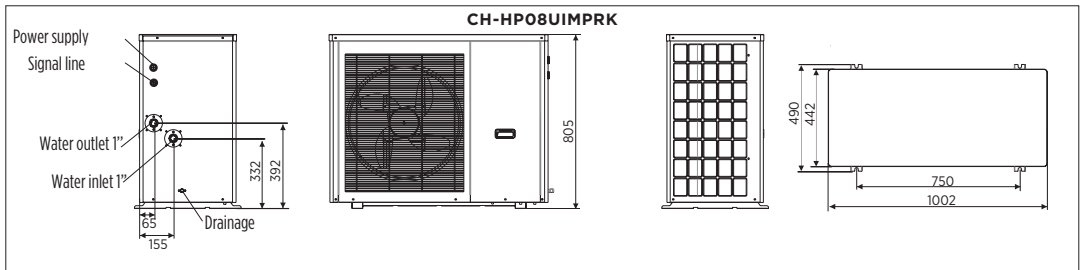

EVIPOWER SERIES

FOR HEATING OR
COOLING AND DHW



ON/OFF



+21°C ... +43°C



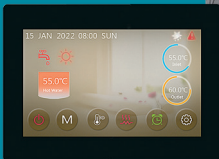

-30°C ... +43°C



EVIPOWER

- ▶ Five operating modes: heating, cooling, DHW, heating + DHW, cooling + DHW;
- ▶ Convenient wired touchscreen display for control;
- ▶ Frost protection;
- ▶ Compressor overheating protection;
- ▶ 4G MMN module (Management and Monitoring Network);
- ▶ Cascade control of up to 16 heat pumps via the MXL280 central controller. (only for 42 and 84 kW models)

 -30°C... +43°C	 +60°C Max. water temperature	 Energy Efficiency	 Self-diagnostics	 Auto-protection
 Anti-corrosive Coating	 EVI Compressor	 Timer	 Wired Controller	 Intelligent Defrosting
 Intelligent Control	 4G	 BMS Control Systems		

TECHNICAL PARAMETERS

		CH-HP16UMNM	CH-HP24UMNM	CH-HP42UMNM	CH-HP84UMNM
Heating Capacity ²	kW	15,4	24	42	84
Heating Power Input ²	kW	3.79	5.97	10	20.0
Heating Capacity ²	kW	15.7	22.6	43	86.0
Heating Power Input ²	kW	5.3	8.9	14.5	29.0
SCOP	W/W	3.85	3.78	3.52	2.79
DHW Capacity ¹	kW	18.5	29.1	50	100.0
DHW Power Input ¹	kW	4.14	7.25	10.8	22.0
Cooling Capacity ⁴	kW	10.8	17	27.3	59.0
Cooling Power Input ⁴	kW	4.7	7.84	10.6	21.9
Max. power input	kW	8.1	10.2	16.7	33.5
Max. current input	A	13.5	18.7	25.8	61.5
Power supply	V/ph/Hz	-380-415/3/50			
Compressor quantity		1	2	1	2
Compressor type		EVI Rotary		EVI Scroll	
Fan quantity		2		1	2
Fan power	W	75×2	150×2	1100×1	1100×2
Fan speed	rpm	800		900	
Sound pressure level	dB(A)	55	58	68	73
Piping connection		1 1/4	1 1/2	1 1/2	Flange DN80
Water flow	m ³ /h	2.7	4.1	8.5	17
Water Pressure Drop	kPa	29	43	60	65
Dimensions unit (W×D×H)	mm	995×400×1315	1175×400×1588	1410×854×1912	2180×1080×2100
Dimensions packing (W×D×H)	mm	1070×435×1340	1225×450×1600	1490×1000×2050	2300×1230×2240
Weight Net	kg	132	215	430	778
Weight Gross	kg	147	229	458	814
Refrigerant charge volume R410A	kg	3	2.2×2	9	9×2

1. Ambient temperature - hot water DB/WB 20°C / 15°C, outlet water circulation from 15°C to 55°C;

2. Ambient temperature - heating DB/WB 7°C / 6°C, outlet water 55°C inlet water 50°C;

3. Ambient temperature - heating DB/WB 7°C / 6°C, outlet water 35°C inlet water 30°C;

4. Ambient temperature - cooling DB/WB 35°C / 24°C, outlet water 7°C inlet water 12°C.

OVERALL DIMENSIONS

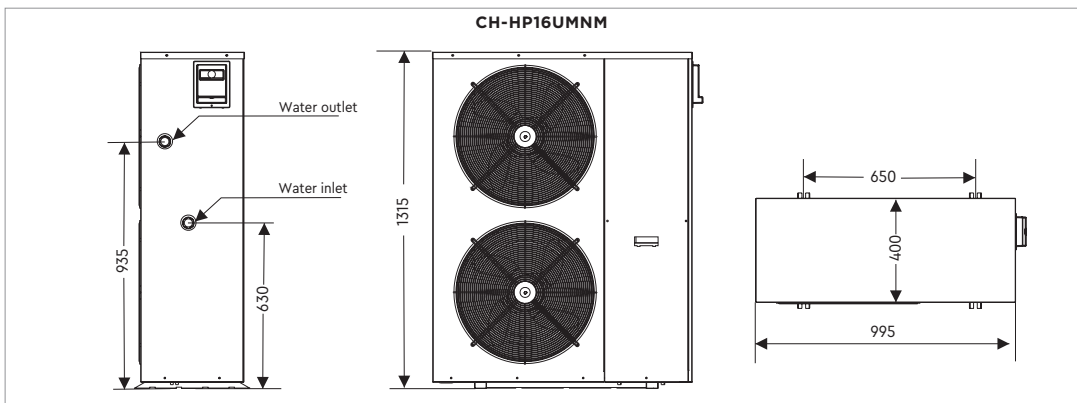

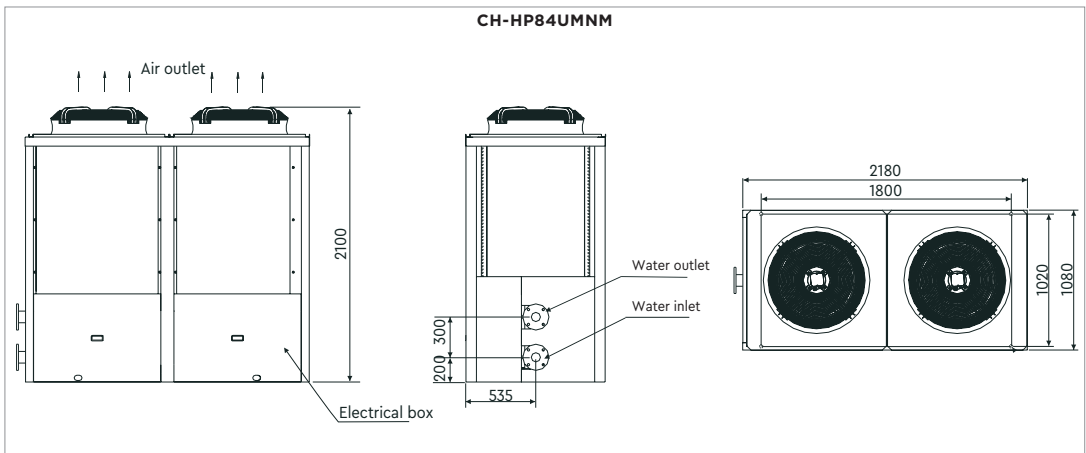
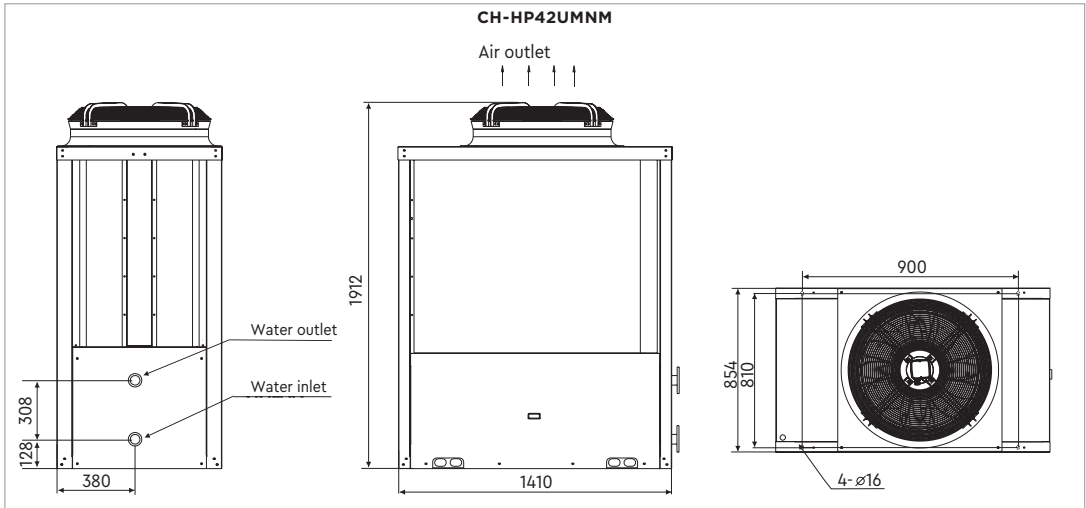
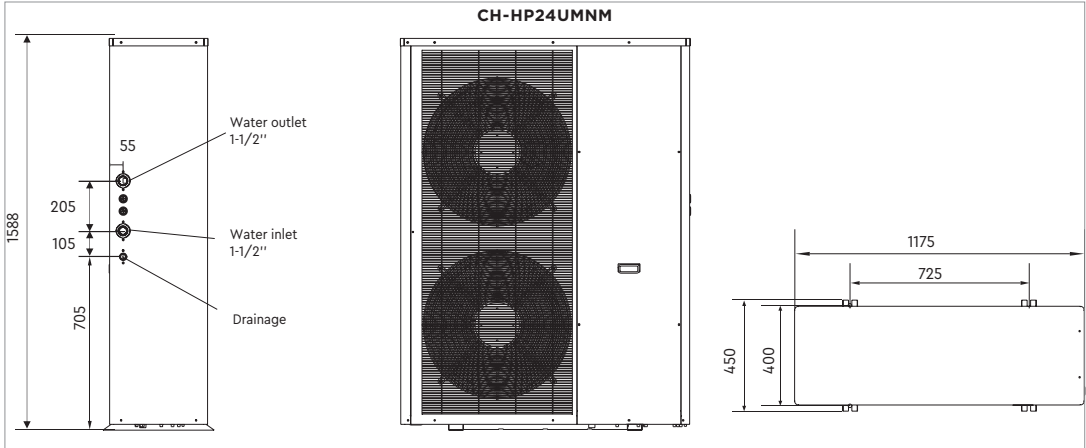

MINIPOWER INVERTER SERIES

FOR HEATING OR
COOLING

- ▶ No need a tank with a built-in heat exchanger. Cascade and weather-dependent control using the CH Smart application within central control comparable with TUYA.
- ▶ Inverter technology, low power-consumption ratio guarantee efficient operation. Controlled refrigeration cycle by pressure switch.
- ▶ Shell and tube heat exchanger (CH-WH5.0MIPRK) saves resources for water preparation.
- ▶ Turns ON/OFF in-built electric heater directly to hot water tank.

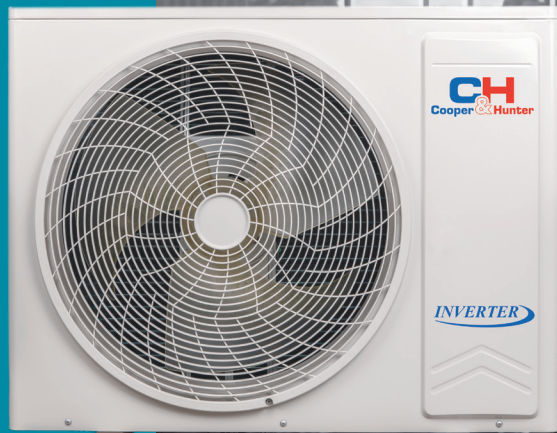

INVERTER

R32
FREON

❄️ +15°C ... +52°C

☀️ -27°C ... +30°C



-27°C... +52°C



+55°C
Max. water temperature



Self-diagnostics



Auto-protection



Anti-corrosive Coating



DC compressor



Timer



Wired Controller



Intelligent Defrosting



Wi-Fi



TECHNICAL PARAMETERS

			CH-HP5.0UIMPRK
Power supply			-220-240V/50 Hz/1 Ph
Cooling ¹	Capacity	kW	3.50
	Power	kW	1.25
Cooling ²	EER1		2.81
	Capacity	kW	5.00
	Power	kW	1.25
Heating ¹	EER2		3.90
	Capacity	kW	3.50
	Power	kW	1.10
Heating ²	COP1		3.20
	Capacity	kW	5.1
	Power	kW	1.4
Heating (35 °C)	COP2		4.00
	SCOP		3.50
Heating (55 °C)	Energy class		A+
	SCOP		2.50
SEER	Energy class		A
SEER			3.50
Dimensions	H x W x D	mm	872x598x372
Weight	Net/Gross		kg
			40/43
Circulation pump	Total head		m
	External head		m
	Water flow		m ³ /h
Water Side Heat exchanger	Type		-
	Quantity		-
Compressor	Type		Double-pipe exchanger
	Manufacturer		1
			Rotary
Refrigerant	Type		GMCC
	Charged volume		-
			R32
Temperature regulating valve	Type		-
Max. power input	Type		Electronic expansion valve
Max. current input	Type		-
Operation range	Heating (water)		1.80
	Cooling (water)		9.00
	Heating (air side)		20-60
	Cooling (air side)		5-25
Sound power level	Nominal		-27-30
			15-52
Sound pressure level	Nominal		61
Piping inlet/outlet	Nominal		52
			1 Male BSP

Rated characteristics are specified for the following conditions: Cooling1: Outside air DB 7 °C, Inlet/outlet water 12/7 °C; Cooling2: Outside air DB 35 °C, Water inlet/outlet 23/18 °C; Heating1: Outside air DB 7 °C/WB 6 °C, Water inlet/outlet 40/45 °C; Heating2: Outside air DB 7 °C/WB 6 °C, Water inlet/outlet 30/35 °C.

OVERALL DIMENSIONS

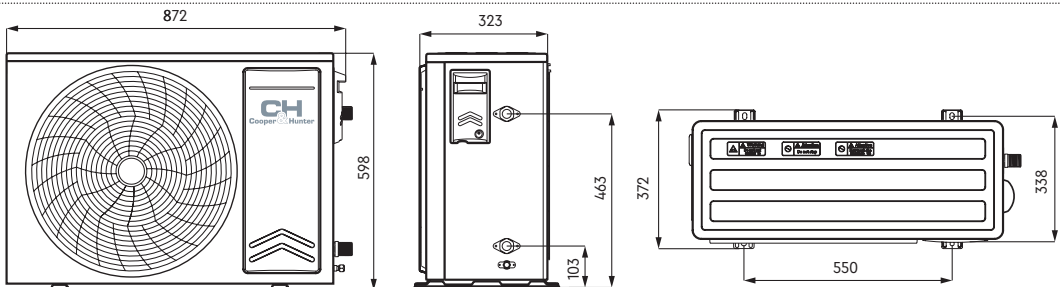

MINIPOWER INVERTER SERIES

FOR DHW

- ▶ Daily timer;
- ▶ Touch control panel;
- ▶ GMCC DC inverter rotary compressor;
- ▶ External unit tray electric heater;
- ▶ Built-in circulation pump;
- ▶ Remote control via Wi-Fi;
- ▶ Control of additional electric heater.



-20°C... +43°C



+55°C
Max. water
temperature



Self-
diagnostics



Auto-
protection



Anti-
corrosive
Coating



INVERTER

DC
compressor



24h

Timer



Wired
Controller



Intelligent
Defrosting



Wi-Fi



TECHNICAL PARAMETERS

		CH-WH5.0MIPRK
Power supply	--	-220-240V/50 Hz/1 Ph
Min./Max. voltage	V	185/264
Heating capacity	W	5000
	Btu/hours	18000
Water flow	l/h	108
Power input for heating	W	1200
Current input for heating	A	5.50
Power input	W	1900
Current input	A	8.9
COP	W/W	4.35
Compressor Trademark	--	GMCC
Compressor type	--	Rotary
Outdoor Unit Air Flow Volume	m ³ /h	1800
Operation Ambient Temperature Range	°C	-20-43
Throttling Method	--	Electronic expansion valve
Defrosting method	--	Automatic defrosting
Moisture protection	--	IP24
Sound pressure level	dB(A)	50
Sound power level	dB(A)	62
Piping inlet/outlet	inch	3/4 Male
Dimensions (W×D×H)	mm	863x598x372
Packing dimensions (W×D×H)	mm	941x663x412
Net weight	kg	35
Gross weight	kg	39
Refrigerant	--	R32
Refrigerant charge	kg	0.4

(1) Testing conditions:
Outdoor temperature: 20 °C DB/15 °C WB, start/end hot water temperature: 15 °C /55 °C

OVERALL DIMENSIONS

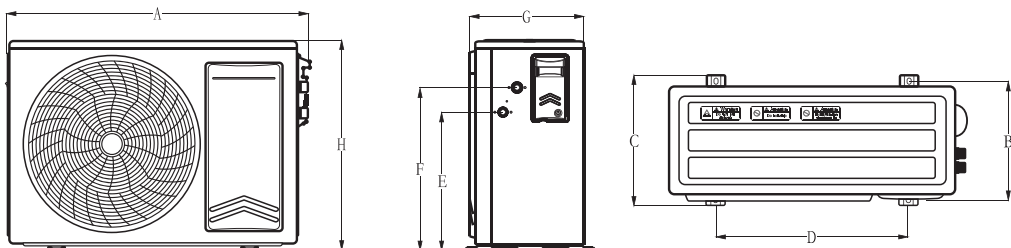

Code	Dimensions	Code	Dimensions
A	863	E	393
B	338	F	463
C	372	G	324
D	550	H	598

WIRED CONTROLLER

1. Operation settings: Hot water, Auto, Turbo, Quiet mode and ECO.
2. Range of temperature settings.
3. On/off timer, range from 00:00 to 23:59.
4. Manual/automatic on/off.
5. Checking the current parameters.
6. Touch buttons.



No.	Button name	Description
1	Mode	Selection of functions Turbo, Quiet, ECO, Standard.
2	Timer	Timer setting.
3	Increase/Up	Setting the operating temperature, setting the timer parameters and others.
4	Decrease/Down	
5	Function	Functions setting.
6	ON/OFF	Device ON/OFF.

Thanks to the Cooper&Hunter's Smart application, you can conveniently and efficiently control heat pumps from anywhere using the mobile Internet. This app gives you full access to the functions and settings of your heat pump, allowing you to change heating and cooling settings from a convenient mobile device.

You can remotely turn on and off the heat pump, change the temperature of the room, configure work schedules, and monitor the energy efficiency of the system. You have options such as «Heating», «Cooling» and «Automatic» modes, as well as the ability to set timers to automatically turn the system on or off at the specified time.

With this app, you can save energy and money by switching your heat pump to a more optimal operating mode according to your schedule and needs. No more going home or looking for the remote control, because all the control is right in your mobile phone.

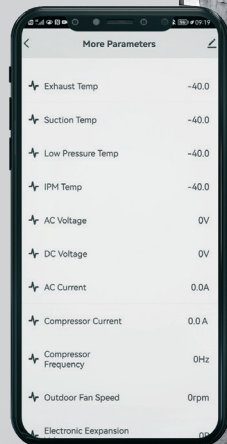
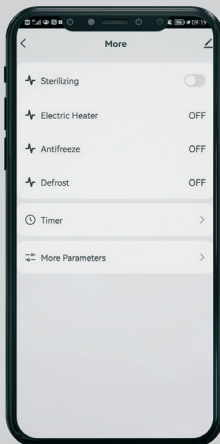
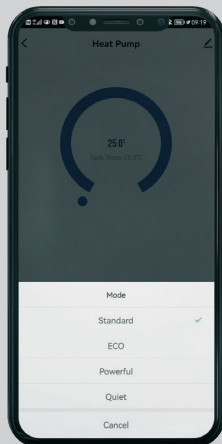

SWIMMING POOL AIR-TO-WATER HEAT PUMPS

DYNAMIC SERIES

❄️ +16°C ... +45°C

☀️ -15°C ... +43°C

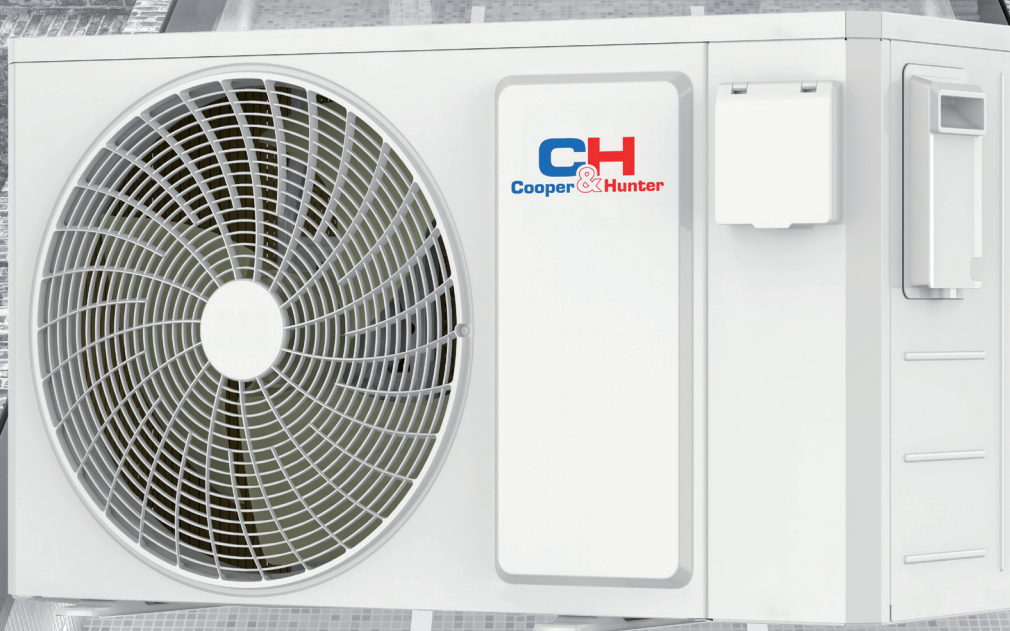

By using a seamless titanium heat exchanger with a rigid polyvinyl chloride (PVC) casing, the C&H swimming pool heat pump has high acid resistance, excellent alkali resistance, excellent corrosion resistance and low flow resistance, making it more suitable for heat exchange of water in swimming pools that are frequently disinfected.



DYNAMIC

- ▶ Titanium heat exchanger;
- ▶ Ozone-safe refrigerant R32;
- ▶ Convenient controller;
- ▶ High efficiency;
- ▶ Wi-Fi remote control;
- ▶ Low noise;
- ▶ Intelligent defrosting system;
- ▶ High accuracy of temperature maintenance;
- ▶ Operating external temperature range:
 - ▶ Heating from -15°C to +45°C
 - ▶ Cooling from +16°C to +45°C;
 - ▶ Water temperature adjustment range +10°C to +45°C
- ▶ Used for pools up to 95 m³.



Titanium heat exchanger



Self-diagnostics



Auto-protection



Anti-corrosive Coating



INVERTER

DC compressor



Timer



Touch control management



Intelligent Defrosting



Intelligent Control



Wi-Fi

REMOTE CONTROL WITH BUILT-IN WI-FI MODULE

Intuitive control panel with built-in Wi-Fi module.

For convenience, the remote control can be moved up to 8m (wire length).

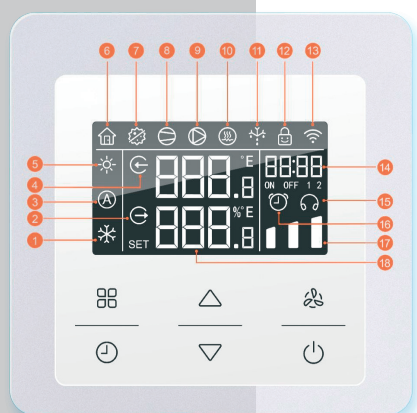

1		Cooling mode
2		Indication of outgoing water (supply); the field also displays the outgoing water temperature.
3		Automatic mode
4		Indication of incoming water (return); the field also displays the incoming water temperature.
5		Heating mode
6		Absence
7		Sterilization
8		Compressor operating status
9		Water pump operating status
10		Auxiliary electric heating
11		Defrost status
12		Child lock
13		Wi-Fi status
14		Timer field
15		ECO timer icon
16		Timer on/off icon
17		Level
18		Temperature range

HEAT PRODUCTION DEPENDENCE GRAPH ON OUTDOOR TEMPERATURE

The use of a DC inverter fan, compressor and electronic expansion valve contributes to constant control of the pool temperature and high-efficiency operation of the system.

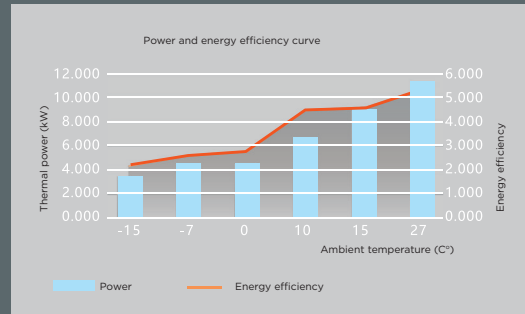
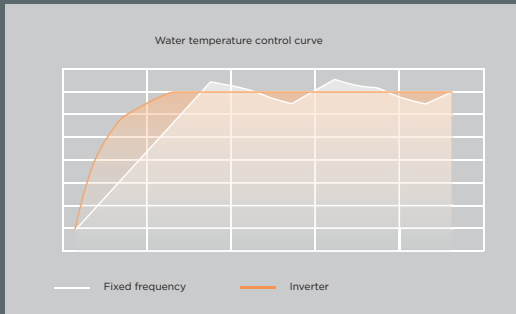

WI-FI CONTROL (EWPE SMART APP)

Thanks to the EWPE Smart app, you can conveniently and efficiently control your heat pump from anywhere using your mobile internet.

This app gives you access to the functions and settings of your heat pump, allowing you to change the heating and cooling parameters from your mobile device.

You can remotely turn the heat pump on and off, change the water temperature, and set operating schedules.

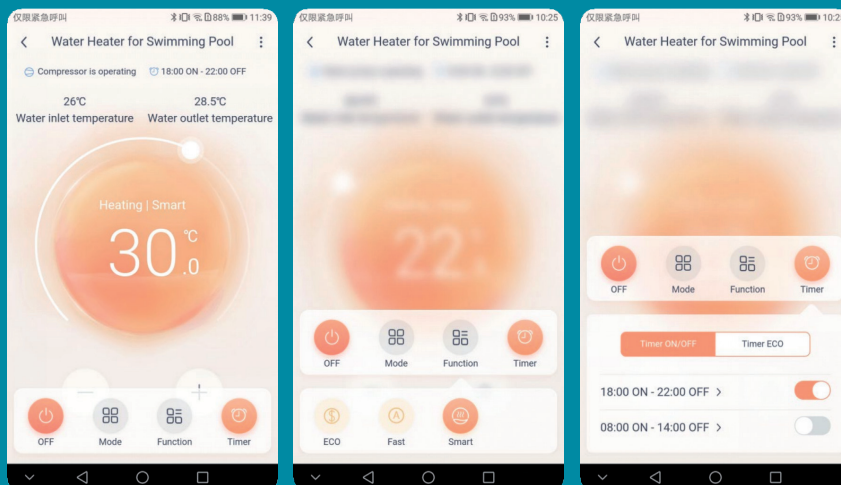

TECHNICAL PARAMETERS

Model			CH-HP060LDIRK	CH-HP095LDIRK
High-temperature & high-humidity heating: ambient temperature: 27°C/80%, 26°C water inlet	Heating capacity	kW	2.2-11.8	5.5-18.8
	COP	W/W	13.0-5.8	11.0-5.2
Medium-temperature & medium- humidity heating: ambient temperature: 15°C/70%, 26°C water inlet	Heating capacity	kW	2.0-8.8	3.0-15.1
	COP	W/W	6.3-4.5	6.0-4.0
Cooling ambient temperature: 35°C/-, 30°C water inlet	Cooling capacity	kW	4.3	7.8
	EER	W/W	3.2	4.0
Maximum power ¹		kW	2.5	4.0
Maximum current ¹		A	11	17.5
Nominal Water flow		m ³ /h	3.8	6.5
Water resistance		kPa	5	12
Noise ²		dB(A)	52	55
Dimension (W×D×H)		mm	980×376×554	1085×402×657
Weight		kg	43	52.5
Hydraulic connection		mm	PVC 50/50	
Compressor		—	Hermetic Rotary DC Inverter Compressor	
Fan motor		—	DC Fan Motor	
Refrigerant		—	R32	
Refrigerant Charge ³		kg	0.52	0.73
Power supply		V/Hz/ph	220-240/50/1	
Protection		—	IPX4	
Max. pool volume ⁴		m ³	60	95
Mode		—	Heating/Cooling/Automatic	

NOTES:

- The above maximum power or maximum current does not include the power or current of an external circulation water pump.
- Noise data is the average sound pressure measured under high temperature and high humidity conditions (dry air 27°C - relative humidity 80% - inlet water temperature 26°C) at a distance of 1 m from the unit.
- This parameter determines the maximum amount of refrigerant that can be charged into the unit.
- The recommended maximum pool volume is calculated based on ideal heating conditions for the pool: well shaded, filtration system running 15 hours per day, water temperature maintained at 26°C, and ambient temperature ≥28°C.

OVERALL DIMENSIONS

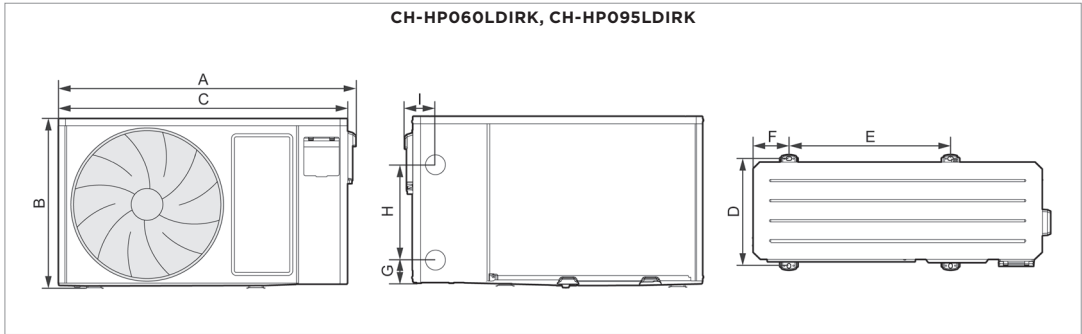

Units of measurement: mm

	CH-HP060LDIRK	CH-HP095LDIRK
A	980	1085
B	554	657
C	945	1060
D	346	371
E	528	570
F	117	160
G	72	82
H	310	340
I	74	87

INSTALLATION ITEMS

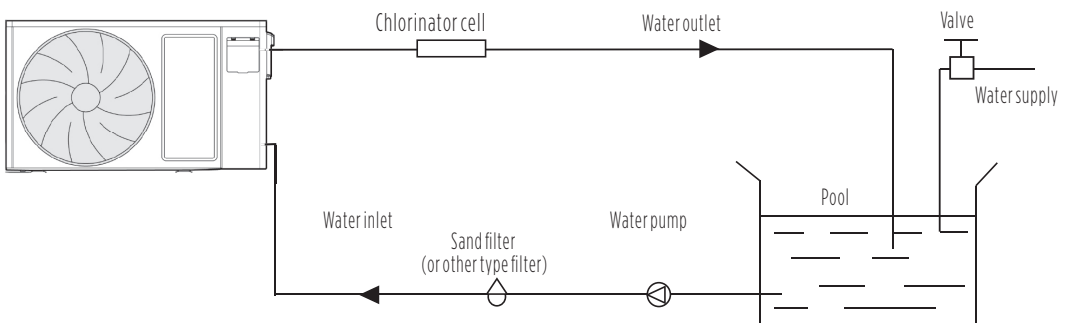

The factory provides only an external unit; other elements in the illustration are necessary components for the heat supply system and provided by the installation organization to the users.

The schematic diagram is for reference only. Please check the water inlet/outlet on the heat pump when installing the water pipe.

The controller can be mounted on the wall.

DEHUMIDIFIER

WITH GLASS
DESIGN PANEL

- ▶ Thanks to improved sound insulation and a DC fan motor, the dehumidifier operates extremely quietly (44-46 dB(A)). This allows the unit to be installed in any room.
- ▶ The dehumidifier creates a warm and comfortable air flow.
- ▶ The heat exchanger is coated with a special golden epoxy resin, a coating with exceptional anti-corrosion properties. This allows for extended service life in rooms with high relative humidity.
- ▶ Modern and sophisticated body design. C&H dehumidifiers for swimming pools are available in two versions, white and black gloss.



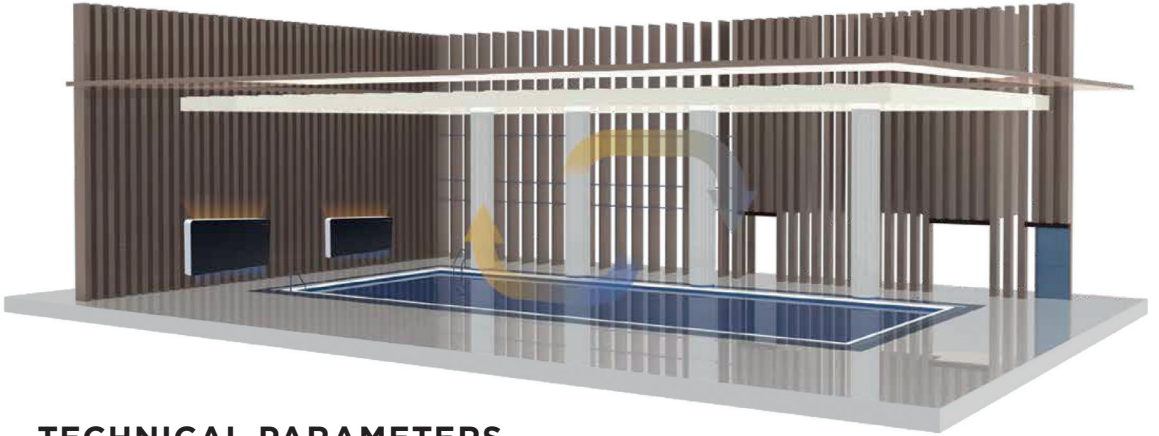

TECHNICAL PARAMETERS

		CH-D22RK (B)	CH-D35RK (B)	CH-D45RK (B)
Dehumidification capacity	l/h	2.2	3.5	4.5
Dehumidification capacity per day	l	53	84	108
Pool surface	m ²	10	15	20
Noise level	dB(A)	44	46	48
Power supply		-220-240V/50 Hz/1 Ph		
Power input	kW	0.892	1.095	1.95
Current input	A	4.0	5.0	8.0
Range of relative humidity	%	40-90	40-90	40-90
Operating temperature range	°C	10 – 36 °C		
Dimensions (LxWxH)	mm	1295x202x647	1495x202x647	1695x202x647
Refrigerant		R32		
Drain pipe	mm	16	16	16

OVERALL DIMENSIONS

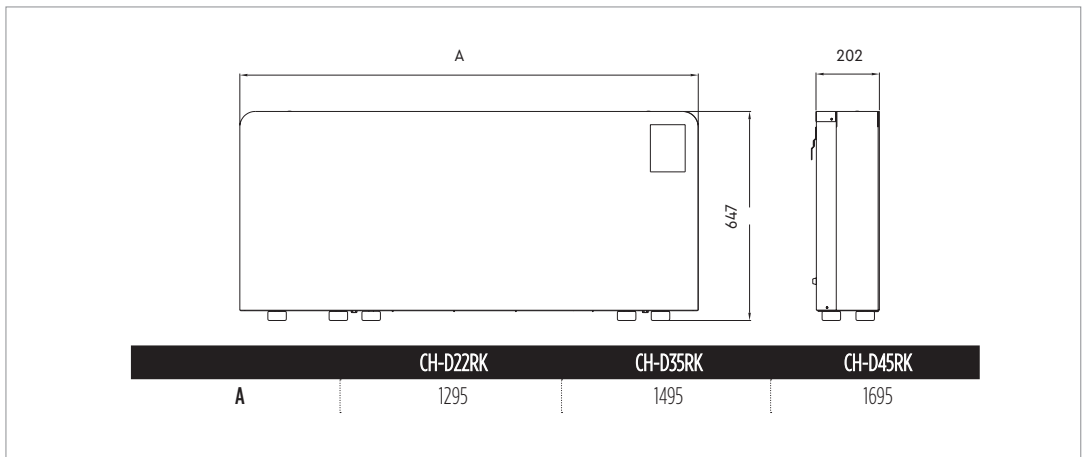

CONSOLE TYPE FANCOILS

WITH GLASS
DESIGN PANEL

- ▶ Two-pipe fan coil.
- ▶ **ULTRA-THIN CASE**
A water fan coil with an ultra-thin design. Compared to a conventional fan coil, it has a thinner body - 130 mm, which significantly saves installation space. The simple and concise exterior will easily fit into your room.
- ▶ **DETAIL-ORIENTED**
Control is carried out using touch buttons on the fan coil panel, which light up brighter when touched in the control area.
- ▶ **SUPER QUIET**
The use of modern fans in combination with special air flow distribution technology makes the units quieter, so quiet that they will not affect your healthy and sound sleep.
- ▶ **WATER CONNECTION**
If desired, water is connected from the right side or left side, which adds flexibility to users during installation work.





HIGH EFFICIENCY

The thermal performance of fan coils is two times higher than the power parameters of ordinary radiators. The distribution of heat between rooms allows you to save 30% of energy consumption compared to conventional heating radiators.

TECHNICAL PARAMETERS

		CH-FK10SW(B)K2	CH-FK18SW(B)K2	CH-FK25SW(B)K2	CH-FK34SW(B)K2	CH-FK44SW(B)K2
Heating: Ambient temperature (DB/WB): 20 °C, Water temperature (inlet/outlet): 60 °C/70 °C						
Heating capacity	W	2250	3950	5750	7200	9400
Water flow	m ³ /h	0,22	0,34	0,49	0,62	0,81
Water pressure drop	kPa	10,6	12,2	26,2	27,5	28,2
Heating: Ambient temperature (DB/WB): 20 °C, Water temperature (inlet/outlet): 45 °C/50 °C;						
Heating capacity	W	1350	2500	3350	4300	5200
Water flow	m ³ /h	0,23	0,43	0,58	0,74	0,89
Water pressure drop	kPa	10,8	13,1	27,5	27,9	28,5
Cooling: Ambient temperature (DB/WB): 27 °C/19 °C, Water temperature (inlet/outlet): 7 °C/12 °C.						
Cooling capacity	W	1000	1900	2500	3500	4350
Water flow	m ³ /h	0,17	0,33	0,43	0,60	0,75
Water pressure drop	kPa	11,1	13,3	27,7	28,3	30,6
Air flow	m ³ /h	160	320	460	580	650
Noise pressure at max air flow	dB(A)	40	44	46	47	48
Noise pressure at min air flow	dB(A)	24	27	28	28	30
Power supply		220-240 V / 50 Hz / 1 Ph				
Power input	W	15	20	23	25	32
Piping inlet/outlet	inch	3/4 Male BSP				
Drainage pipe	mm	16				
Dimensions (D×W×H)	mm	695x130x700	895x130x700	1095x130x700	1295x130x700	1495x130x700
Packing dimensions (D×W×H)	mm	740x180x730	940x180x730	1140x180x730	1340x180x730	1540x180x730
Net weight	kg	18	21	24	28	32
Gross weight	kg	20	24	27	31	36

OVERALL DIMENSIONS

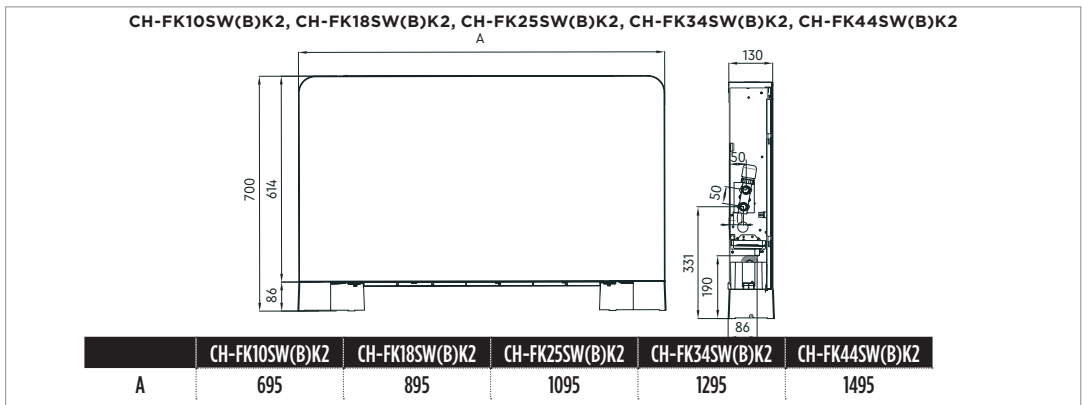

FLOOR-CEILING TYPE FANCOILS

- ▶ Two-pipe fan coil.
- ▶ Fin-type heat exchanger with copper tubes and aluminum fins, with the possibility of choosing the side of the connections (left/right).
- ▶ Three speeds of the centrifugal low-noise fan.
- ▶ Direct-drive motor equipped with internal thermal protection and condenser. Housing made of pre-painted, galvanized steel sheet, covered with a protective coating of PVC film, complete with sound insulation, grilles made of heat-resistant ABS plastic.
- ▶ Condensate collection tray with drainage included - anti-condensate insulation.
- ▶ Filter made of regenerated polypropylene.

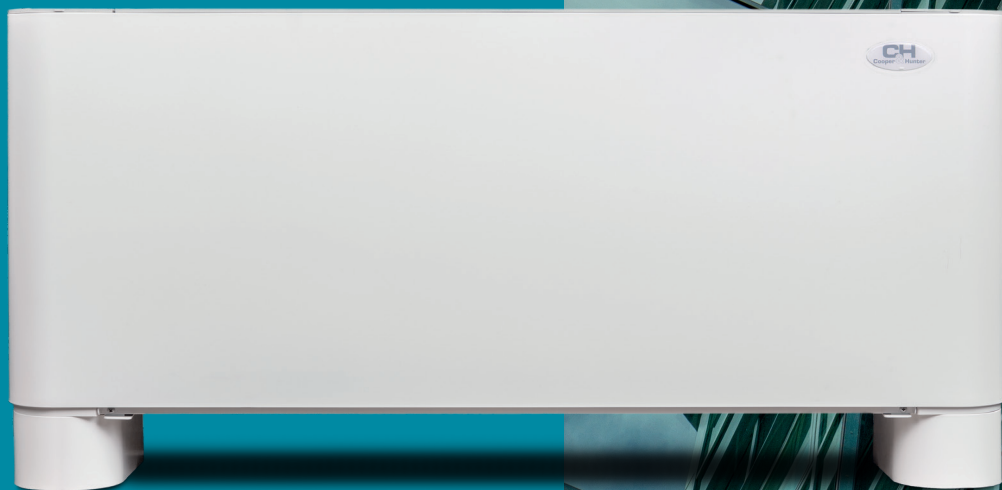

KJR-18B/E-B

*option



KJRP-86I/MFK-E

*option

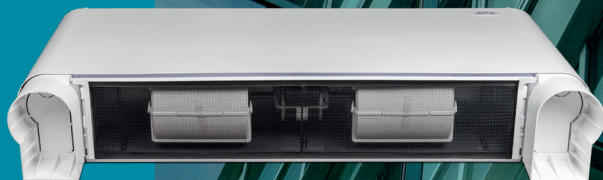

TECHNICAL PARAMETERS

		CH-FFC22K2	CH-FFC30K2	CH-FFC42K2	CH-FFC53K2	CH-FFC67K2	CH-FFC82K2	
Power supply		-220-240 V/50 Hz/1 Ph						
Air flow (H/M/L)*	m ³ /h	255/192/139	425/284/184	595/450/319	800/574/404	1150/885/591	1300/1132/836	
	CFM	150/113/82	250/167/109	350/265/188	471/338/258	677/521/348	766/667/492	
External static pressure		0						
Cooling	Capacity (H/M/L)*	kW	2.25/1.85/1.46	3.05/2.26/1.63	4.20/3.38/2.48	5.35/4.25/3.31	6.75/5.80/4.24	8.25/7.52/5.87
	Water flow (H/M/L)*	l/h	386/317/249	523/387/280	720/580/425	917/729/567	1157/995/727	1414/1289/1007
	Water pressure drop (H/M/L)*	kPa	49.29/33.22/21.74	33.66/19.73/10.61	44.3/29.14/16.91	68.61/46.24/29.71	46.5/33.73/18.66	74.76/63.56/40.28
Heating	Capacity (H/M/L)*	kW	2.35/1.87/1.40	3.15/2.09/1.38	4.10/3.25/2.39	5.70/4.36/3.22	7.15/5.81/4.04	8.50/7.60/5.72
	Water flow (H/M/L)*	l/h	403/320/240	540/357/237	703/557/409	977/747/552	1226/996/692	1457/1302/981
Water pressure drop (H/M/L)*		kPa	36.51/24.61/16.1	25.84/13.93/6.77	39.56/26.06/14.63	59.39/36.80/21.25	44.27/30.11/15.39	65.06/49.83/30.28
Power input (H/M/L)*		W	40/24/15	47/26/14	51/32/19	91/54/35	110/89/64	118/104/82
Current input		A	0.17/0.10/0.07	0.20/0.11/0.06	0.22/0.14/0.08	0.40/0.24/0.15	0.48/0.39/0.28	0.51/0.45/0.36
Sound power level (H/M/L)*		dB(A)	53/47/39	47/38/32	52/45/37	59/51/43	62/56/46	62/58/50
Fan motor		Type	AC fan motor					
		Quantity	1					
Fan		Type	Centrifugal, forward-curved Blades					
		Quantity	1	2	3	3		
Coil		Row	4					
		Max. pressure	1.6					
Dimensions (W×D×H)		mm	495×200×790	495×200×1020	495×200×1240	495×200×1240	495×200×1360	591×200×1360
Packing dimensions (W×D×H)		mm	595×300×895	595×300×1125	595×300×1345	595×300×1345	595×300×1465	695×300×1465
Net weight		kg	16.7	20.8	25.4	25.4	28.5	34.0
Gross weight		kg	22.2	26.8	32.4	32.4	36.0	42.0
Piping inlet/outlet		inch	3/4" Female BSP					
Drainage pipe		mm	OD Ø 18.5					

Notes

1. H: high fan speed; M: average fan speed; L: low fan speed
2. Cooling conditions: inlet water 7°C, outlet water 12°C, inlet air temperature 27°C DB, 19°C WB.
3. Heating conditions: inlet water 40°C, outlet water 45°C, inlet air temperature 20°C DB.
4. Noise is tested in a semi-anechoic test room

OVERALL DIMENSIONS

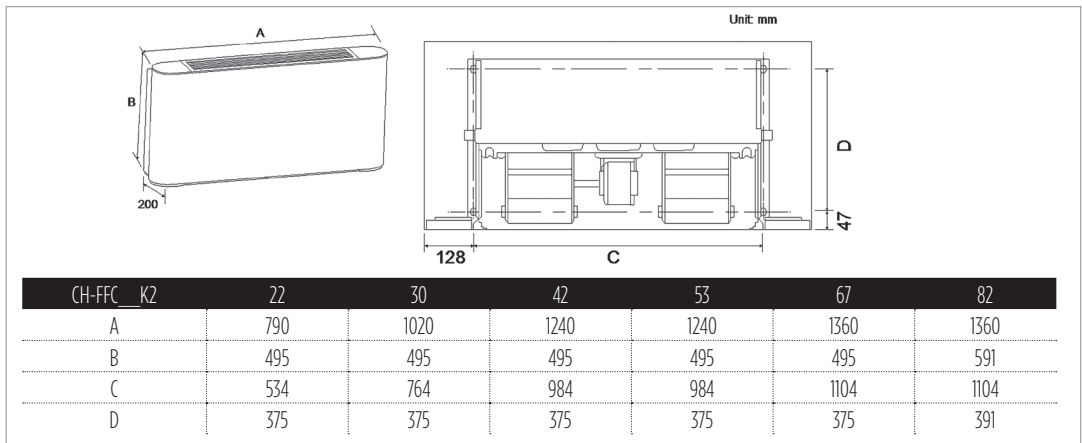

DUCT TYPE FANCOILS

- ▶ Two-pipe fan coil.
- ▶ Connection of pipelines on the left or right; Patented design that can prevent strong noise.
- ▶ Aerodynamic air distribution;
- ▶ The design of the fan coil considers various installation options, which allows you to optimize the performance of work;
- ▶ Possibility of fresh air intake;
- ▶ Air recirculation;
- ▶ Washable filter;
- ▶ Metal filter frame — standard, additional aluminum frame is possible on request;
- ▶ Air outlet flange and multi-directional retractable filter can be optional;
- ▶ Additional wired controller provides simplicity and flexibility in controlling the unit.

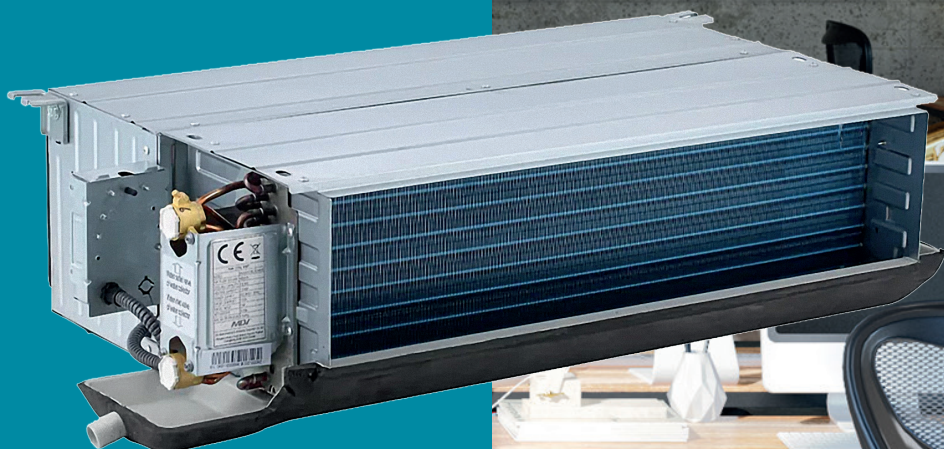

KJR-18B/E-B

*option



KJRP-861/MFK-E

*option

TECHNICAL PARAMETERS

		CH-FDH25K2 CH-FDVH25K2	CH-FDH34K2 CH-FDVH34K2	CH-FDH44K2 CH-FDVH44K2	CH-FDH50K2 CH-FDVH50K2	CH-FDH60K2 CH-FDVH60K2	
Power supply		-220-240 V/50 Hz/1 Ph					
Air flow (H/M/L)*	12Pa/30Pa/50Pa (H/M/L)*	m ³ /h CFM	340/275/190 200/162/112	510/416/286 300/245/168	680/551/381 400/324/224	850/691/476 500/407/280	1020/826/571 600/486/336
	Standard external static pressure Pa FDH model: 30; FDVH models: 50						
Cooling²	Capacity 30Pa (H/M/L)*	kW	2.50/2.20/1.90	3.40/3.00/2.50	4.41/3.80/3.30	5.00/4.30/3.80	6.00/5.00/4.60
	50Pa (H/M/L)*	kW	2.50/2.20/1.90	3.40/3.00/2.50	4.41/3.80/3.30	5.00/4.30/3.80	6.00/5.00/4.60
	Water pressure drop 30Pa (H/M/L)*	kPa	27/24/19	24/19/14	24/21/16	30/23/18	38/28/25
Heating³	Capacity 30Pa (H/M/L)*	kW	4.10/3.61/3.12	5.67/5.00/4.17	7.35/6.17/5.50	8.60/7.40/6.54	9.98/8.32/7.65
	50Pa (H/M/L)*	kW	4.10/3.61/3.12	5.67/5.00/4.17	7.35/6.17/5.50	8.60/7.40/6.54	9.98/8.32/7.65
	Water pressure drop 30Pa (H/M/L)*	kPa	22/20/16	20/16/12	20/17/13	24/19/15	31/23/20
Water flow	30Pa (H/M/L)*	l/min	7.17/6.31/5.45	9.75/8.60/7.17	12.64/10.89/9.46	14.33/12.33/10.89	17.20/14.33/13.19
	50Pa (H/M/L)*	l/min	7.17/6.31/5.45	9.75/8.60/7.17	12.64/10.89/9.46	14.33/12.33/10.89	17.20/14.33/13.19
Power input	30Pa (H/M/L)*	W	42/36/29	57/40/32	70/47/40	83/67/56	102/78/64
	50Pa (H/M/L)*	W	48/38/31	64/50/38	81/64/57	97/65/55	114/85/76
Sound pressure level	30Pa (H/M/L)*	dB(A)	37/30/23	40.5/33/26	40.5/34/26	42/36/27	43/37/27
	50Pa (H/M/L)*	dB(A)	40/32/24	42/34/31	44/37/33	46/40/33	47/42/33
Fan motor	Type	Low noise 3-speed AC capacitor motor					
Fan	Quantity	1	1	1	1	1	
	Type	Centrifugal, forward-curved Blades					
Coil	Quantity	1	2	2	2	2	
	Row	3					
Coil	Max. working pressure	1.6MPa					
	Diameter	7					
Dimensions (W×D×H)	mm	627×240×455	772×240×455	907×240×455	907×240×455	1002×240×455	
Packing dimensions (W×D×H)	mm	682×270×500	817×270×500	952×270×500	952×270×500	1047×270×500	
Net weight	kg	11.9	14.1	16.9	18.0	20.5	
Gross weight	kg	14.0	16.3	19.5	20.7	23.6	
Piping inlet/outlet	inch	3/4 Female BSP					
Drainage pipe	inch	3/4 Female BSP					

- Notes:
 1. B: high fan speed; C: average fan speed; H: low fan speed;
 2. Cooling conditions: inlet water 7°C, outlet water 12°C, inlet air temperature 27°C DB/19.5°C WB, available fan pressure;
 3. Heating conditions: inlet water 60°C, inlet air temperature 21°C DB/15°C, available fan pressure. Water consumption: the same under cooling conditions;
 4. The above sound level is tested in a semi-anechoic room according to the GB/T19923 standard when the device is without accessories and operating in dry conditions. The background noise level is 17.5 dB(A).
 5. Air consumption is determined at the nominal pressure of the fan without filter and exhaust air adapter in dry conditions and 20 °C DB.
 6. The connection of the unit from the left side to the right can be changed at the installation site, but the cooling and heating capacity should be multiplied by the correction factor of 0.9;
 7. The performance data on the above sheet has been tested at 220V-50 Hz.

OVERALL DIMENSIONS

	CH-FDH25K2 CH-FDVH25K2	CH-FDH34K2 CH-FDVH34K2	CH-FDH44K2 CH-FDVH44K2	CH-FDH60K2 CH-FDVH60K2	CH-FDH72K2 CH-FDVH72K2	CH-FDH80K2 CH-FDVH80K2	CH-FDH112K2 CH-FDVH112K2	CH-FDH130K2 CH-FDVH130K2
A	475	620	755	850	1025	1215	1505	1745
B	443	588	723	818	993	1183	1473	1713
C	443	588	723	818	993	1183	1473	1713
D	415	560	695	790	965	1155	1445	1685
E	627	772	907	1002	1177	1367	1657	1897
F	513	658	793	888	1063	1253	1543	1783

TECHNICAL PARAMETERS

			CH-FDH72K2 CH-FDVH72K2	CH-FDH80K2 CH-FDVH80K2	CH-FDH93K2 CH-FDVH93K2	CH-FDH112K2 CH-FDVH112K2	CH-FDH130K2 CH-FDVH130K2
Power supply			-220-240V/50 Hz/1 Ph				
Air flow (H/M/L)*	30Pa (H/M/L)*	m ³ /h	1190/936/682	1360/1102/762	1700/1416/978	2040/1652/1142	2380/1928/1333
		CFM	700/551/401	800/648/448	1000/833/576	1200/972/672	1400/1135/785
	50Pa (H/M/L)*	m ³ /h	1190/936/682	1360/1102/762	1700/1416/978	2040/1652/1142	2380/1928/1333
		CFM	700/551/401	800/648/448	1000/833/576	1200/972/672	1400/1135/785
Standard external static pressure		Pa	FDH model: 30; FDVH models: 50				
Cooling ²	Capacity	30Pa (H/M/L)*	7.20/6.10/5.50	8.03/6.80/6.10	9.27/8.00/6.80	11.20/10.00/8.50	13.00/11.20/9.80
		50Pa (H/M/L)*	7.20/6.10/5.50	8.03/6.80/6.10	9.27/8.00/6.80	11.20/10.00/8.50	13.00/11.20/9.80
	Water pressure drop	30Pa (H/M/L)*	30/23/20	40/31/25	40/31/23	40/32/24	50/39/31
		50Pa (H/M/L)*	30/23/20	40/31/25	40/31/23	40/32/24	50/39/31
Heating ³	Capacity	30Pa (H/M/L)*	12.00/10.17/9.00	13.60/11.35/10.33	16.00/13.81/11.74	19.20/17.14/14.57	22.16/19.09/16.71
		50Pa (H/M/L)*	12.00/10.17/9.00	13.60/11.35/10.33	16.00/13.81/11.74	19.20/17.14/14.57	22.16/19.09/16.71
	Water pressure drop	30Pa (H/M/L)*	24/19/16	32/25/20	32/25/19	32/26/20	40/32/25
		50Pa (H/M/L)*	24/19/16	32/25/20	32/25/19	32/26/20	40/32/25
Water flow	30Pa (H/M/L)*	l/min	20.64/17.49/15.77	23.02/19.49/17.49	26.57/22.93/19.49	32.11/28.67/24.37	37.27/32.11/28.09
	50Pa (H/M/L)*	l/min	20.64/17.49/15.77	23.02/19.49/17.49	26.57/22.93/19.49	32.11/28.67/24.37	37.27/32.11/28.09
Power input	30Pa (H/M/L)*	W	121/88/72	135/100/80	169/149/133	206/157/126	245/179/145
	50Pa (H/M/L)*	W	131/110/80	169/122/83	204/141/125	243/173/128	291/259/221
Sound pressure level	30Pa (H/M/L)*	dB(A)	46/39/31	44.5/40/33	47/42/35	48/42/35	49.5/43/36
	50Pa (H/M/L)*	dB(A)	48/43/37	50/39/36	51/45/40	52/46/40	53/49/42.5
Fan motor	Type	Low noise 3-speed AC capacitor motor					
	Quantity	1	2	1	2	2	
Fan	Type	Centrifugal, forward-curved Blades					
	Quantity	2	3	4	4	4	
Coil	Row	3					
	Max. working pressure	MPa	1.6MPa				
	Diameter	mm	7				
Dimensions (W×D×H)	mm	1177×240×455	1367×240×455	1367×240×455	1657×240×455	1897×240×455	
Packing dimensions (W×D×H)	mm	1192×270×500	1382×270×500	1382×270×500	1672×270×500	1957×270×500	
Net weight	kg	20,5	25,5	26,0	33,8	35,3	
Gross weight	kg	23,6	29,1	29,7	39,5	39,8	
Piping inlet/outlet	inch	3/4 Female BSP					
Drainage pipe	inch	3/4 Female BSP					

Notes:

1. B: high fan speed; C: average fan speed; H: low fan speed;

2. Cooling conditions: inlet water 7°C, outlet water 12°C, inlet air temperature 27°C DB/19.5°C WB, available fan pressure;

3. Heating conditions: inlet water 60°C, inlet air temperature 21°C DB/15°C, available fan pressure, Water consumption: the same under cooling conditions;

4. The above sound level is tested in a semi-anechoic room according to the GB 19232 standard when the device is without accessories and operating in dry conditions.

5. The background noise level is 17.5 dB (A);

6. Air consumption is determined at the nominal pressure of the fan without filter and exhaust air adapter in dry conditions and 20 °C DB;

7. The connection of the unit from the left side to the right can be changed at the installation site, but the cooling and heating capacity should be multiplied by the correction factor of 0.9;

8. The performance data on the above sheet has been tested at 220V-50 Hz;



WALL TYPE FANCOILS WITH BUILT-IN 3-WAY VALVE

- ▶ Two-pipe fan coil.
- ▶ New control panel provides more customization options;
- ▶ Water pipe with three connection options: left/right/rear;
- ▶ Horizontal and vertical air flow adjustment possible with rotary louver;
- ▶ Built-in 3-way valve with electric drive;
- ▶ Remote control with LCD display standard delivery, wired controller available on request;
- ▶ Four-speed motor with super high speed for more choice.

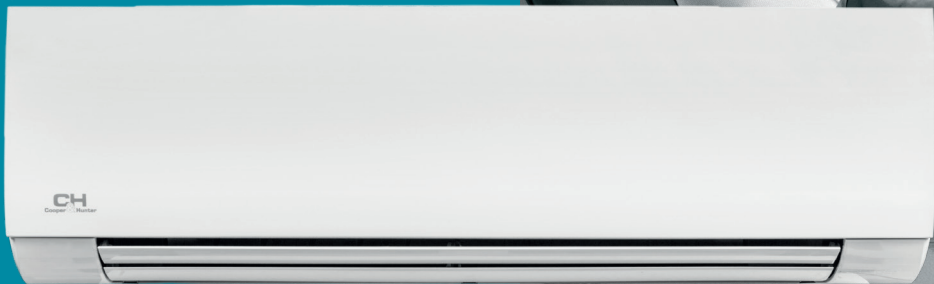
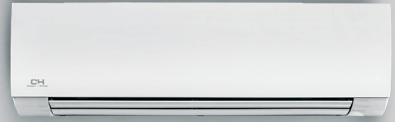

KJR-29B1/BK-E

*option

TECHNICAL PARAMETERS

		CH-FW025K2A	CH-FW030K2A	CH-FW040K2A	CH-FW050K2A	CH-FW060K2A	
Power supply		-220-240V / 50 Hz / 1 Ph					
Air flow (H/M/L)*	m ³ /h	435/396/342	523/426/351	660/534/480	841/723/594	915/836/714	
	CFM	256/233/201	308/251/206	388/314/282	495/425/349	538/492/420	
Cooling	Capacity (H/M/L)*	kW	1.94/1.84/1.68	2.64/2.4/1.99	2.94/2.58/2.34	4.01/3.61/3.1	4.61/4.33/3.84
	Water flow (H/M/L)*	m ³ /h	0.35/0.33/0.3	0.47/0.43/0.36	0.53/0.46/0.42	0.72/0.65/0.56	0.83/0.78/0.69
	Water pressure drop (H/M/L)*	kW	31.6/28.6/25.2	37.5/30/24	57.2/47.6/38.7	47.1/33.5/29.7	51/39.5/34
Heating	Capacity (H/M/L)*	m ³ /h	2.34/2.15/1.94	2.9/2.6/2.22	3.46/2.75/2.52	4.39/3.8/3.27	4.55/4.2/3.82
	Water flow (H/M/L)*	kW	0.43/0.39/0.35	0.53/0.47/0.4	0.63/0.5/0.46	0.8/0.69/0.6	0.83/0.76/0.69
	Water pressure drop (H/M/L)*	kPa	35.2/34.9/30	39.3/31.5/25	70.8/55.1/46.2	48.6/40.8/31.7	48/43/33
Power input (H/M/L)*	W	35/32/31	47/43/39	50/51/47	60/54/48	72/60/55	
Current input	A	0.11	0.17	0.18	0.22	0.29	
Sound pressure level	dB(A)	30/24/20	35/29/24	37/31/26	39/33/28	40/34/29	
Fan motor	Type	Low noise 3-speed fan motor					
	Quantity	1					
Fan	Type	Tangential fan					
	Quantity	1					
Coil	Row	2					
	Dimensions (W*D*H)	mm	635*315*26.74		785*315*26.74		
	Fin type	Hydrophilic aluminum					
	Circuit	5					
	Max. working pressure	MPa	1.6				
Casing	Dimensions (W*D*H)	mm	915*230*290		1072*230*315		
	Packing dimensions (W*D*H)	mm	1020*390*315		1180*415*315		
	Net weight	kg	13	13.3		15.8	
	Gross weight	kg	16.3	16.7		19.4	
Piping	Inlet/outlet	inch	3/4 Female BSP				
	Drainage	mm	OD Ø 20				

Notes:

1. B: high fan speed; C: average fan speed; H: low fan speed
2. Cooling conditions: inlet water 7°C, outlet water 12°C, inlet air temperature 27°C DB, 19°C WB. Heating conditions: inlet water 40°C, outlet water 45°C, inlet air temperature 20°C DB.
3. Noise is tested in a semi-anechoic test room

OVERALL DIMENSIONS

	A	B	C	D	E
CH-025(030,040)-K2A	732	915	290	663	233
CH-050(060)-K2A	892	1072	315	813	237

CASSETTE TYPE FANCOILS

- ▶ Water cooling/heating (2 pipes).
- ▶ Low height for easy installation.
- ▶ Single-phase 3-speed direct drive fan with low noise.
- ▶ Copper tube/aluminum fin heat exchanger.
- ▶ Aluminum ring fins with hydrophilic coating (optional).
- ▶ Housing made of electroplated zinc coating for maximum corrosion protection.
- ▶ Zinc-coated steel drain pan.



KJR-29B1/BK-E

*option



OVERALL DIMENSIONS

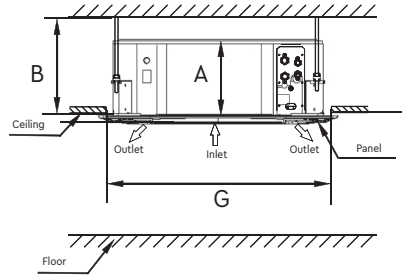
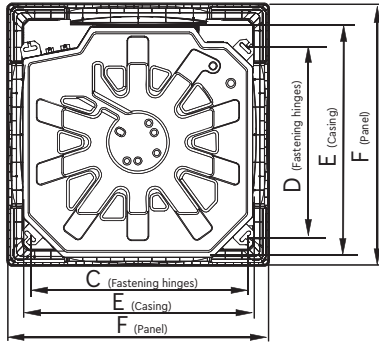

	A	B	C	D	E	F	G
CH-FC030K2, CH-FC040K2, CH-FC050K2	261	>300	545	523	575	647	600
CH-FC060K2, CH-FC075K2	230	>260	780	680	840	950	880
CH-FC085K2 - CH-FC150K2	300	>330	780	680	840	950	880

TECHNICAL PARAMETERS

			CH-FC030K2	CH-FC040K2	CH-FC050K2	CH-FC060K2	CH-FC075K2	CH-FC085K2	CH-FC100K2	CH-FC120K2	CH-FC150K2	
Air flow	High	m ³ /h	510	680	850	1000	1250	1400	1600	2000	2550	
	Medium		440	580	730	850	1060	1190	1360	1700	2170	
	Low		360	480	600	720	900	1010	1150	1440	1840	
Cooling capacity (High speed)	W	3000	3700	4500	5700	7000	7270	8220	10390	12900		
	Btu/h	10236	12624	15354	19510	23840	24800	28050	35450	44010		
Heating capacity (High speed)	W	4000	5100	6000	9660	11550	12420	13850	17580	17600		
	Btu/h	13648	17401	20472	32970	39420	42360	47240	60000	60050		
Noise level (High speed)	dB(A)	36	42	45	45	46	47	48	49	50		
Water flow	l/min	8.7	10.7	12.9	16.4	20	20.8	23.6	29.8	36.9		
Water pressure drop	kPa	14	15	16	23.8	25.2	27	31.2	44	40		
Coil	Row		2									
	Circuit		5	6	7	8		12				
Fan motor	Type		Low noise 4-speed fan motor									
	Quantity		1									
Indoor unit	Power input	W	35	60	75	120	125	145	150	185		
	Dimensions (W×D×H)	mm	575×261×575			840×230×840			840×300×840			
	Packing dimensions (W×D×H)	mm	705×340×705			955×260×955			955×330×955			
	Net/Gross Weight	kg	17.5/22.5			25/31 (27/33)			30.5/37.2 (33/40)		35/42	
Panel	Dimensions (W×D×H)	mm	647×50×647						950×46×950			
	Packing dimensions (W×D×H)	mm	715×123×715						1035×90×1035			
	Net/Gross Weight	kg	3/5						6/9			
Control Mode		Remote controller										
Piping	Inlet/outlet		3/4" Female BSP									
	Drainage		EVA+LDPE 3/4" Male BSP									

Note: 1. All performance data above is for 0 Pa external static pressure.
 2. Cooling capacity test conditions: inlet air temperature: 27 DB °C/19 WB °C, inlet water temperature 7°C, water temperature difference 5 °C.
 3. Heating power test conditions: Temp. 21 DB °C, inlet water temperature 60 DB °C The volume of air and water is the same as cooling.
 4. The noise level is checked in an anechoic room.

MARKINGS

	Titanium heat exchanger	A specially designed titanium heat exchanger for the needs of heat pumps for swimming pools. Guarantees reliable and long-term operation of the heat pump for swimming pools. Thanks to a special titanium alloy, the heat exchanger is protected from the effects of water disinfectants.
	Heating/Cooling	A wide range of temperatures ensures stable and efficient operation of the heat pump at any outside temperature. Regardless of the season, the heat pump efficiently provides you with heat or cold and DHW. A guarantee of reliable operation of the heat pump all year round!
		Stable temperature control of hot water supply and ensuring the comfort of your home. A heat pump heats water for hot water supply, thereby providing your home with comfort and independence from central hot water supply systems.
	Energy Efficiency	The energy efficiency class determines the degree of efficiency of the heat pump. Thanks to a simple gradation of efficiency, the degree of efficiency of the heat pump is easily determined.
	Self-diagnostics	The system constantly monitors possible malfunctions of the heat pump. Sensors signal in time about possible limit states of the heat pump, and reliable automation notifies about probable malfunctions.
	Auto-protection	Protects the heat pump from voltage drops, which in turn guarantees stable and safe operation during critical voltage surges in the power grid. This protects the electrical equipment of the heat pump.
	Anti-corrosive Coating	A specially developed coating of the heat exchanger protects the heat exchanger itself from the influence of external factors, such as the sea climate or high air humidity. The anti-corrosion coating makes the heat pump heat exchanger reliable and durable.
	Golden Fin Coating	The innovative Golden Fin coating ensures the stability of the heat exchanger surface and increases its service life. It also extends the service life of the heat pump in regions with high humidity, in places where the air is contaminated with sand, salt, industrial smoke and other pollutants.
	DC compressor	The compressor's DC motor allows less electricity consumption. Which is especially urgent during the constant operation of the heat pump. Makes the system highly efficient and economical.
	2-Stage Compressor	Thanks to the 2-stage design of the compressor, it was possible to increase the temperature range of the heat pump without significant loss of efficiency. Which, in turn, significantly decreases energy consumption of the heat pump at extremely low (up to -30 °C) temperatures outside.
	EVI Compressor	Increases the operating range of the heat pump, reduces the temperature in the compressor and increases the level of performance of the heat pump. EVI technology saves heat pump energy resources at low outside temperature in winter.
	Timer	Thanks to the timer, you have the opportunity to program the start of the heat pump. This function will be especially useful when there is a need to save energy for heating or cooling the room. Or in the case of supporting your home in the absence of people. The timer can be configured both by hours and days of the week.
	Touch Screen Control	5-inch color touch-screen panel with a large number of control functions of the heat pump. Allows you to control the modes, set the temperature, carry out actual monitoring of the heat pump and adjust the comfort functions.
	Wired Controller	Allows you to install the controller in a separate special room. Which, in turn, allows only authorized personnel to control the heat pump. The wired controller has all the necessary control functions to implement professional control of the heat pump.
	Intelligent Control	A wide range of functions allows you to manage, monitor, adjust and control the operation of the heat pump. Provides additional options for controlling the heat pump.
	BMS Control Systems	The remote monitoring interface allows you to control the heat pump via the Modbus protocol and integrate it into the Building Management System (smart building management system).
	Intelligent Defrosting	The function implements a more advanced defrosting system of the heat pump. The defrosting program is not activated after fixed time intervals, as it is implemented in standard systems, but only when defrosting is necessary.
	Wi-Fi	Easy and relaxed control of the heat pump from anywhere. It is enough just to activate the necessary software for Wi-Fi and you will be able to control the heat pump remotely. Temperature control, changing operating modes and many other useful functions are available through the mobile application.
	4G	The 4G MMN (Management & Monitoring Network) function makes it possible to control the heat pump using mobile communication. A special slot for a SIM card allows you to activate communication with the heat pump using mobile networks.

HYPER POWER INVERTER

CH
Cooper & Hunter

SERIE

SCOP = 5.15



cooperandhunter.com

+75°C

SG
READY

R290
FREON

55°C
A+++

0°C ... +43°C

-30°C ... +43°C

40 dB(A)

CH Cooper & Hunter

CHV6

